



# ***Europe's Access to Deep Space***

The Deep Space Ground Station  
in Australia

# High-Tech Communication with Deep Space Satellites

Deep space missions, where considerable amounts of data have to be transferred over long distances, require larger antenna sizes. The antenna of ESA's Deep Space Ground Station at New Norcia is one of the largest in the world used for Telemetry and Telecommand (TT&C) applications and represents one of the two jewels in the ESTRACK network of ground stations operated by ESA and

controlled from the European Space Operations Centre (ESOC) in Germany.

The system incorporates a 35m antenna on a full-motion pedestal with a beam waveguide feed system, cooled S- and X-band Low Noise Amplifiers and 20-kilowatt S- and X-band transmitters. The overall height of the antenna is around 40 metres

and the total weight of the structure and equipment above the antenna pedestal interface weighs approximately 630 tonnes.

The weight of the main reflector is 120 tonnes, and the total movable structure amounts to around 580 tonnes. The ground station with its exceptional antenna is required for Telemetry and Telecommand (TT&C) of deep space and high-elliptical-orbit missions. Among the most important of these missions are Rosetta, Mars Express and Venus Express.

In the case of Rosetta, the New Norcia Ground Station sends commands to the spacecraft and receives data from it. Rosetta is up to 900 million kilometres away from the Earth, more than six times the distance from the Earth to the Sun.



*The ESA deep space antenna in New Norcia, Australia*

## New Norcia Station Supports Scientific Missions

### **Rosetta**

Rosetta was launched on 2 March 2004. After entering orbit around the comet Churyumov-Gerasimenko in 2014, it will release a lander onto the comet, then spend the next two years orbiting it as it heads towards the Sun. The prime scientific objective is to study the origin of comets, the relationship between cometary and interstellar

material, and its implication with regard to the origin of the solar system.

### **Mars Express**

ESA's first-ever mission to Mars was launched on 2 June 2003. For Europe, the Mars Express mission marked the start of a new and exciting era in planetary exploration. Mars Express comprises an orbiter with seven onboard

scientific instruments that probe the planet's atmosphere, structure and geology, looking for, among other things, evidence of hidden water. Data are transmitted over a distance of up to 450 million kilometres.

### **Venus Express**

As the closest planet to the Earth, Venus is a natural target for missions.



*Rosetta*



*Mars Express*



*Venus Express*

DSA 1 (NEW NORCIA)			DSA 2 (CEBREROS)		
Parameter	Mirror 6 (M6)	Mirror 4 (M4) optional Ka-Band Rx	Mirror 6 (M6)	Mirror 7 (M7) optional Ka-Band Tx	Unit
Transparent Bands	X-Band Tx: 7,145-7,235 Rx: 8,400-8,500	Ka-Band Rx: 31,800-32,300	Ka-Band Tx: 34,200-34,700 Rx: 31,800-32,300	Ka-Band Tx Tx: 34,200-34,700	MHz
Reflecting Bands	S-Band Tx: 2,025-2,120 Rx: 2,200-2,300	S-Band Tx: 2,025-2,120 Rx: 2,200-2,300	X-Band Tx: 7,145- 7,235 Rx: 8,400- 8,500	Ka-Band Rx Rx: 31,800-32,300	MHz
		X-Band Tx: 7,145-7,235 Rx: 8,400-8,500			

Table 1: New Norcia and Cebros frequency capabilities

Communicating with a spacecraft over these long distances implies very stringent radio frequency requirements on the ground station antenna system, as weight and energy constraints limit the transmit power and size of the antennas on board the spacecraft.

The key radio frequency performance requirements for the ESA Deep Space Antennas (DSA) are given in Table 1. The ground station must provide sensitive receivers and powerful transmitters coupled to a high-gain antenna to allow reliable communications with

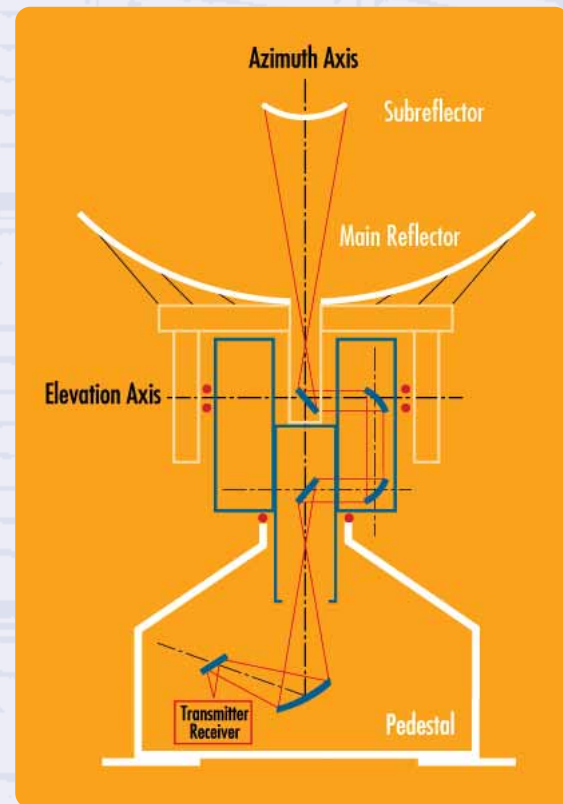
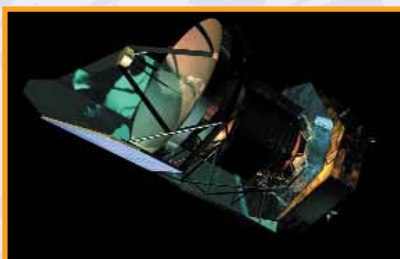

Figure 1: New Norcia antenna schematic

It was out of the limelight during the last decade, however, despite several scientific puzzles: what are the characteristics of the atmosphere? How does it circulate? How does the upper atmosphere interact with the solar wind? Launched on 9 November 2005, Venus Express is the first spacecraft to perform a global investigation of the Venusian atmosphere and of the



Herschel

plasma environment to help answer these questions.

#### Herschel

Herschel will be the largest space telescope of its kind when launched in 2008 together with Planck. Its 3.5 m mirror will collect long-wavelength infrared radiation from some of the coolest and most distant objects in the Universe. It will be the only space observatory to cover the range from far-infrared to submillimetre wavelengths.

#### Planck

Planck will look back at the dawn of time, close to the Big Bang, and will observe the most ancient radiation in

the Universe known as the "Cosmic Microwave Background." Planck will analyse the CMB for clues about how clusters of galaxies and even individual galaxies formed.

#### LISA Pathfinder

The 2009 LISA Pathfinder mission will test the general concepts and technologies needed for highly accurate



Planck

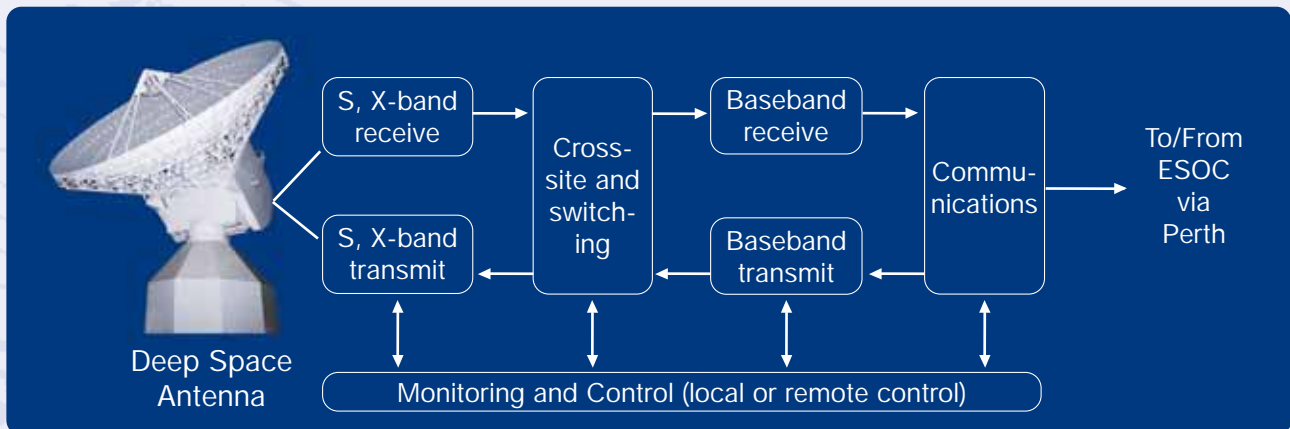

Antenna height	40 metres
Weight of reflector	120 → 100 tonnes
Movable part elevation	375 → 300 tonnes
Movable part El & Az	580 → 500 tonnes
Fixed part azimuth	80 → 120 tonnes
Total weight	630 tonnes

*Table 2: New Norcia antenna physical metrics*

the spacecraft over great distances. The solution requires a big antenna with narrow beam width and consequently high pointing accuracy requirements. Smooth motion by the antenna servo system and stiffness of the mechanical structure under typical environmental conditions are critical parameters in achieving the required performance.

The antenna is complemented by standard ESA baseboard equipment, installed in a separate building. Advanced digital technology is applied to receivers, demodulators and the ranging equipment, which is needed to determine the distance to, and the orbit of, the spacecraft.

formation flying and precise measurement of the separation between two very distant spacecraft. This technology is essential for future ESA missions, such as LISA, which aim to detect subtle gravitational waves.

### Gaia

Gaia is a global space astrometry mission. Its goal is to make the largest,

most precise map of our galaxy by surveying an unprecedented number of stars – more than a thousand million. It is expected to discover hundreds of thousands of new celestial objects, such as extra-solar planets and failed stars called brown dwarfs.

### BepiColombo

Consisting of two orbiters, Bepi-

Colombo will provide the most complete exploration yet of Mercury, the innermost planet. This mission will help reveal information on the composition and history of Mercury, and the history and formation of the inner planets in general, including Earth. One component of BepiColombo will map the planet and another will investigate its magnetosphere.



*LISA Pathfinder*



*Gaia*



*BepiColombo*

# Years of Experience in Mission Operations



## ESA – The European Space Agency

The European Space Agency is Europe's gateway to space. Its mission is to shape the development of Europe's space capability and ensure that investment in space continues to deliver benefits to the citizens of Europe. By coordinating the financial and intellectual resources of its 17 member states, it can undertake programmes and activities far beyond the scope of any single European country.

The Agency's projects are designed to discover more about the Earth, its immediate space environment, the solar system and the Universe, as well as to develop satellite-based

### ESOC's tasks in the preparation and support of satellite missions

**Mission Conception**  
• Mission Analysis

**Mission Preparation**  
• Flight Dynamics  
• Operations  
• Ground Systems  
• Integration and Tests

**Satellite Launch**  
• Establish contact to the spacecraft

**Mission Operations**  
• Spacecraft Operations  
• Station Network Operations  
• Rescue Operations

technologies and services, and to promote European industries. ESA also works closely with space organisations outside Europe to share the benefits of space with the whole of mankind.

## ESOC – The European Space Operations Centre

Located in Darmstadt, Germany, ESOC is the mission control centre of the European Space Agency. It is

responsible for all spacecraft operations, the establishment and running of the necessary ground infrastructure as well as communication networks. Since its creation in 1967, ESOC has planned missions, operated more than 50 satellites and ensured that spacecraft meet their mission objectives.

ESOC can support many spacecraft for different types of missions at the same time. To be able to communicate with satellites in a variety of orbits and conditions, ESOC engineers develop and maintain a global network of ground stations known as ESTRACK, where the antennas and systems are located. These stations are distributed around the world – some of them in Europe, up to the polar circle in Kiruna (Sweden), others as far away as Kourou (French Guiana) and Australia.



# Where Benedictine Contemplation meets the High-tech Future



*The monastery at New Norcia*

The Deep Space Ground Station at New Norcia is ESA's second ground station in Australia. For more than ten years, ESOC has maintained an S-band and an X-band station approximately 20 kilometres north of the city of Perth on the western coast of Australia. It is being used for the X-Ray Astronomy Mission XMM-Newton during its routine phases as well as

for the Launch and Early Orbit Phase (LEOP) for other missions.

New Norcia, a small historical town, is located about 90 minutes north of Perth. The ground station facility builds a bridge between the 150-year-old tradition of its Benedictine monastery and the high-tech world of spaceflight. In addition, the New Norcia station is also used for the Ulysses and SOHO spacecraft, jointly operated by ESA and NASA at the Jet Propulsion Lab (JPL) in California and Goddard Space Center in Maryland, respectively.

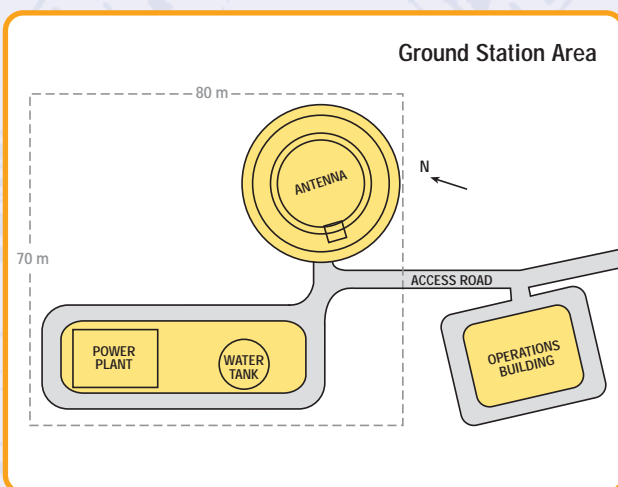

**European Space Agency**  
**Agence spatiale européenne**

**ESA Communication Office**  
ESOC, Robert-Bosch-Strasse 5, D-64293 Darmstadt, Germany  
Tel +49 61 51 90 26 96 · Fax +49 61 51 90 29 61  
[www.esa.int](http://www.esa.int) · [www.esa.int/esoc](http://www.esa.int/esoc)

**New Norcia Ground Station**  
Xantic BV, Perth International, Telecommunications Centre  
P.O. Box 1115, Wangara, W.A. 6065 Australia  
Tel +61 9 3 02 20 00 · Fax +61 9 3 43 26 71