

The MAXUS-8 Sounding Rocket Campaign

ESA's next sounding rocket mission, MAXUS-8, is set to be launched on 26 March from the Esrange Space Centre just outside of Kiruna, Northern Sweden. It will be carrying four vitally important experiment modules that will supply a wealth of data covering research in material science and biology as well as carrying an additional technology demonstrator. These experiments will be the foundation for advancements across many industries helping for example with the future production of new lightweight aircraft engine turbines and the production of new catalysts for chemical reactors and hydrogen fuel cells, as well as answering fundamental research questions in both scientific disciplines.



The MAXUS 7 sounding rocket prior to launch (Image:SSC)

This is the eighth campaign using a MAXUS sounding rocket, and will provide 12-13 minutes of stable weightless conditions to the more than

800kg of research equipment and additional systems it is carrying. Sounding rockets are a key platform for research within ESA's Directorate of Human Spaceflight providing an important, cost-effective and independent means for Europe to carry out research requiring access to short-term periods of weightlessness with a relatively quick turnaround of results, as well as providing precursor testing to research equipment which could eventually be launched to the International Space Station.

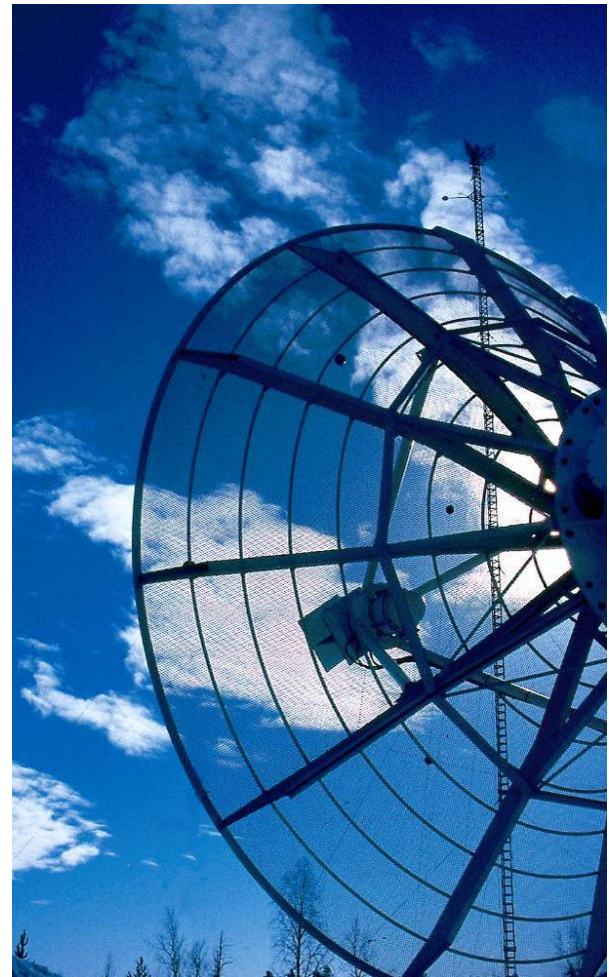

A tracking antenna at the Esrange Space Centre (Image: ESA)

The MAXUS sounding rocket programme is funded by ESA through the European Programme for Life and Physical Science in Space (ELIPS) with the sounding rocket and launch services provided to ESA by an industrial joint venture between EADS Astrium and the Swedish Space Corporation.

MAXUS-8 Launch Profile



The launch of MAXUS 7 on 2 May 2006 (Image: SSC)

Launch to landing of the single stage MAXUS-8 sounding rocket will take only 26 minutes. The 17m long MAXUS-8 includes a 6.5m-long fuselage which contains the four experiment modules to be launched. The sounding rocket has a mass of 12.3



A radar engineer monitors the flight of MAXUS 6 on 22 November 2004 (Image: SSC)

tonnes when it lifts off from the launch pad at Esrange. Alongside the launch tower, the ground station at ESRANGE, will be used to track MAXUS-8 during its short flight and “talk” to the instruments on board via telemetry and telecommand channels as well as receiving video feed.



Scientists monitoring test data during the MAXUS 6 flight (Image: SSC)

The scientists will also be able to monitor their individual experiments on board. The information they receive will be complemented by the data safely embedded in the experiment modules to be retrieved after landing.



Screen capture of MAXUS main engine stage following separation (Image:SSC)

The MAXUS solid rocket booster will finish burning after a total of around one minute after launch, followed a few seconds later by jettison of the rocket’s nose cap. About 90 seconds after lift off the main engine stage separates from the payload section. The Rate Control System with its

nitrogen thrusters is now activated to stabilise the payload and provide for optimal weightless conditions. After a few seconds, with deactivation of the Rate Control System, the research payloads are now experiencing weightlessness on a steep unpowered parabolic trajectory.

The payloads continue their ascent for another six minutes to an altitude of around 750 km (around twice the altitude of the ISS) before the descent back into earth's atmosphere begins. Along with the experiment modules the retrievable payload includes a parachute-based recovery system, a telemetry and telecommand module and a TV module.

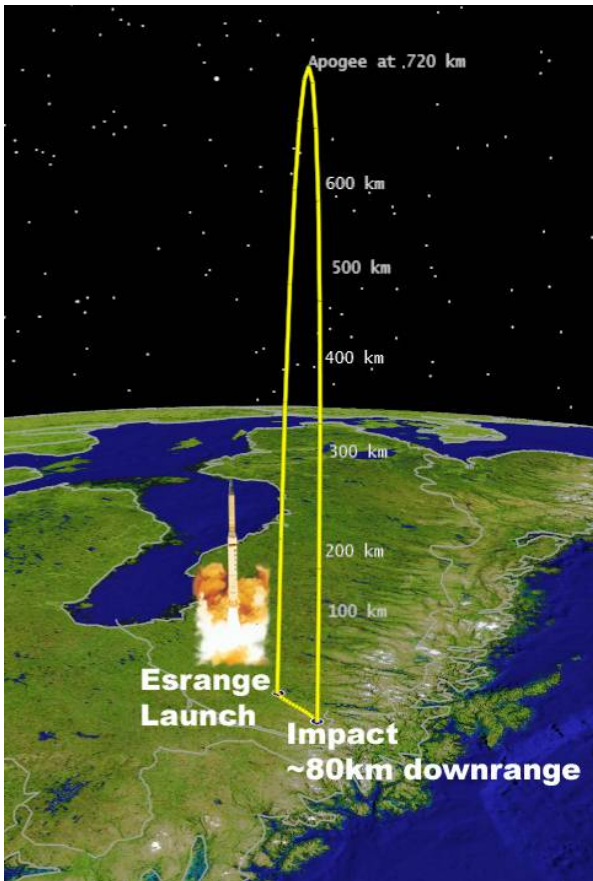

Graphic providing an idea of a MAXUS launch profile
(Image: SSC)

At around 14 minutes after launch the weightless phase is finished. The Rate Control System thrusters are again activated and the payloads are placed in the correct orientation for reentry. At almost 15 minutes after lift off the MAXUS enters the atmosphere travelling at around 4.5 km/s (Mach 13). 50 seconds later the heatshield is jettisoned followed seven seconds later by the

opening of a drogue parachute to slow the MAXUS payloads down. Eight seconds later at an altitude of about 5 km the huge main parachute opens to slow further down the MAXUS payload to allow it to make a soft enough landing in the snowy tundra region north of Esrange where it is retrieved around an hour after landing.



Top: MAXUS 7 payload following landing on 2 May 2006.
Bottom: Helicopter retrieving a sounding rocket payload following landing (Images: SSC)

ESA and Sounding Rockets

The MAXUS-8 sounding rocket campaign builds on almost 30 years of extensive research experience using sounding rockets by the European Space Agency starting with their first experiment on the German TEXUS-6 sounding rocket flight in 1982.

The most prolific use of this type of research by ESA has been undertaken using the TEXUS sounding rocket with the number of experiments funded by ESA now approaching 100. This included the first experiments using the Electro Magnetic Levitator during the TEXUS-42, -44 and -46 campaigns. The launch of the Electro Magnetic Levitator on TEXUS-42 in December 2005 was the first launch of an experimental payload as part of the highly successful IMPRESS project, which accounts for two experiments on the MAXUS-8 flight which are done in combination with MAP experiments in ESA's ELIPS programme (details see ESA Research Programme on MAXUS-8).

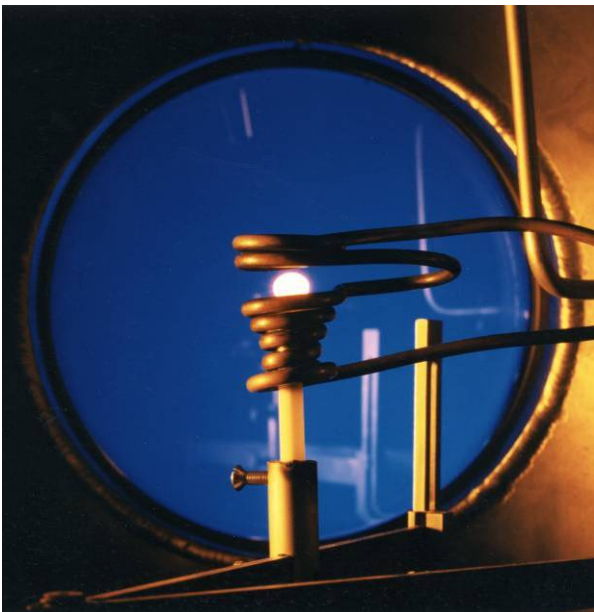

The Electro Magnetic Levitator jointly developed by ESA and DLR permits the accurate property measurements of highly-reactive liquid metal alloys. (Image:DLR)

In a similar vein ESA has participated in all 11 campaigns of the Swedish MASER sounding rocket since its first launch in 1987. Both the TEXUS and MASER had the capability to launch a research payload of around 400kg and provide about 6 minutes of weightlessness. The European MAXUS sounding rocket programme, which was

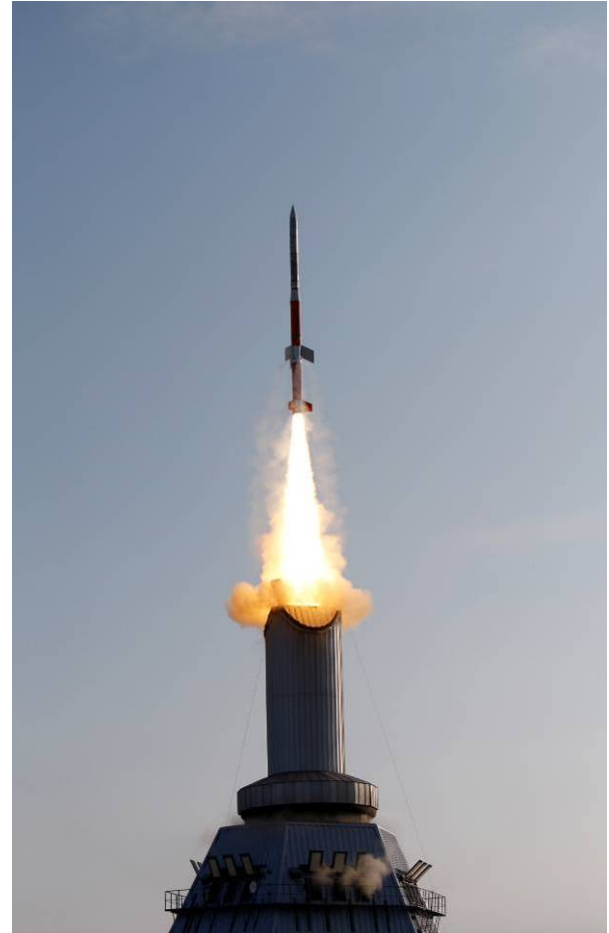

Launch of MASER-11 on 15 May 2008 (Image: SSC)

initiated in 1990 provided the potential to launch twice the mass of TEXUS and MASER and provide 12-13 minutes of weightlessness. ESA has funded all eight MAXUS sounding rocket campaigns since they started. With ESA's additional participation in four MiniTEXUS sounding rocket campaigns, which have the capability to launch smaller research payloads (up to 100 kg) for a shorter amount of time (3-4 minutes of weightlessness) ESA has and continues to have a great deal of flexibility in its strategy to obtain the maximum possible out of its sounding rocket research.

ESA Research Programme on MAXUS-8

The results of all three material science experiments taking place on MAXUS-8 will help to make fundamental improvements as well as cost/fuel-saving changes across numerous industries such as in aerospace and the automotive industry. Two of the three material sciences experiments stem from the extremely successful joint ESA/European Commission IMPRESS* (InterMetallic Processing in Relation to Earth and Space Solidification) project. The 5-year multi-million Euro IMPRESS research project involved 150 scientists and 40 project partners including universities, research establishments and industry. On the ESA side IMPRESS flight experiments are implemented in synergy with Microgravity Application Projects (MAP) within the European Programme for Life and Physical Science in Space (ELIPS). Hence these flight experiments are carried out in combination with applied material science experiments on MAXUS-8. The biology experiment flying on MAXUS-8 will provide essential data with respect to mechanisms of gravity perception and is also part of ESA's ELIPS programme.

Material Science Research Solidification of new titanium-aluminide alloys

This combined IMPRESS/ELIPS experiment will give the science team a chance to answer two important questions: How does gravity affect the alloy's behaviour, as it transforms from liquid to solid? And how does this shape the structure that forms during this solidification process? By varying different process parameters such as temperature gradients, it becomes possible to study other phenomena such as structural transition, segregation of alloying elements and effects due to adding small nucleating particles, known as grain refiners. The sounding rocket furnace of MAXUS-8 enables the simultaneous processing of four titanium-aluminide samples at different boundary temperatures up to a maximum of 1700°C.



Centrifugally-cast titanium-aluminium-based low-pressure turbine blades (Image: ACCESS, Germany)

Comparison between sounding rocket and ground experiment samples will help pinpoint the effects of gravity on casting alloys. These results are of paramount importance for industrial applications and will be exploited to enhance the predictive capability of computer models applied to

commercial casting processes. All these studies will ultimately help the production, of a new generation of lightweight and fuel-saving turbine blades for aeroplane jet engines with half the density of conventional turbine blades.



Results of this experiment will help with the future production of lightweight turbine blades for aerospace jet engines. Shown is a close up of an engine from an Airbus A300 used as part of ESA's 46th Parabolic Flight Campaign (Image: N. Sentse)

Science Team: Y. Fautrelle, O. Budenkova, INPG, St.Martin d'Hères, France; S. Rex, ACCESS, Aachen, Germany; D.Browne, S.M^cFadden, University of Dublin Ireland; L. Froyen, KU-Leuven, Belgium; A.Kartavykh, IKMP, Moscow, Russia.

Agglomeration of nickel nano-particles

This experiment also part of the IMPRESS project and will study the agglomeration of nickel particles first evaporated and then condensed by using a specially-designed cylindrical reactor. The focus is on the way that these nano-particles of nickel cluster together into large fluffy agglomerates when the effect of sedimentation due to gravity is removed.

Small amounts of nickel will be evaporated at 2000°C using a clever heating technique inspired by the filament of a light bulb. The nickel vapour is carried through the reactor by a stable flow of inert argon gas, where the particles will eventually cluster together.

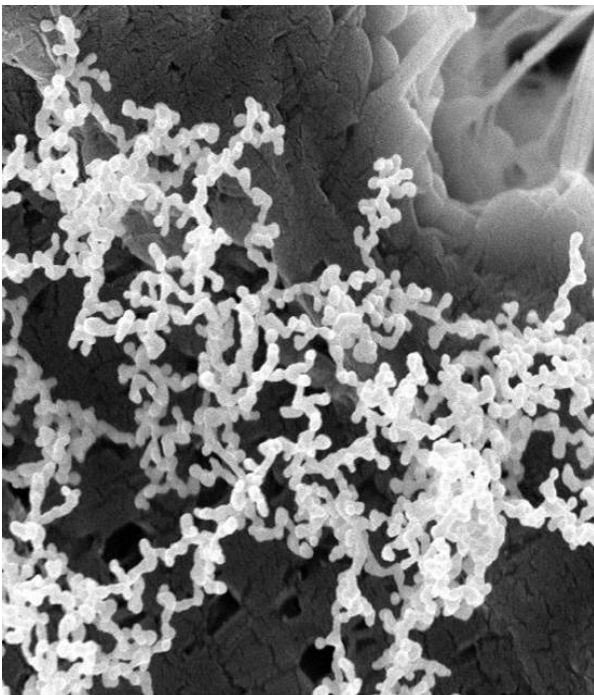

Metal nano-particles produced in weightlessness via an evaporation-condensation process. (Image: IFAM, Bremen, Germany)

The magnetic interactions among the nickel particles will also play a relevant role. By changing the flow rate of the argon, one can adjust the time in flight of the nickel particles. This in turn affects the form of the resulting nickel clusters and strands. At the end of the reactor tube, those agglomerates will be captured by a dedicated sample collector.

The post-flight analysis by electron microscope will tell us more about the shape and structure of the particle clusters. It is expected that very large

porous clusters will form in weightlessness, but how exactly this occurs without the effects of gravity can only be determined after the mission.



Commercial alkaline fuel cell (Image: Hydrocell Oy, Finland)

This research will lead to important concepts for the design of new catalysts, nano-magnets and particular classes of sensors.

Science Team: B. Günther, S. Lösch, Fraunhofer IFAM, Bremen, Germany

X-ray monitoring of liquid diffusion in metallic alloys (XRMON)

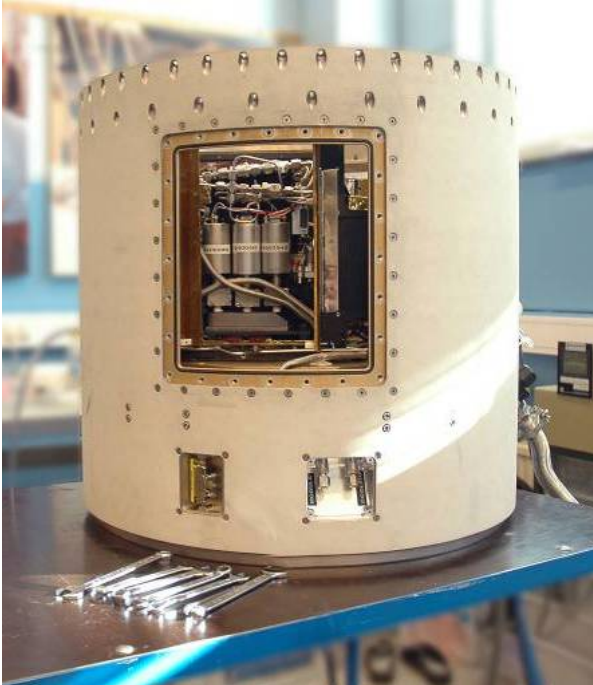

The experiment module during preparation at the Esrange Space Centre (Image: SSC)

The third experiment covers an ESA Microgravity Application Project (MAP). The objective of this research is to investigate diffusive processes in melts of metallic and semiconductor alloys. Nowadays the knowledge of diffusion coefficients in melts is becoming increasingly important, as the casting industry demands more and more accurate simulation models, in order to reduce scrap rates and manufacturing costs. Accurate data on diffusion is a crucial input to these numerical models and will lead to more reliable simulations and cost-saving predictions.

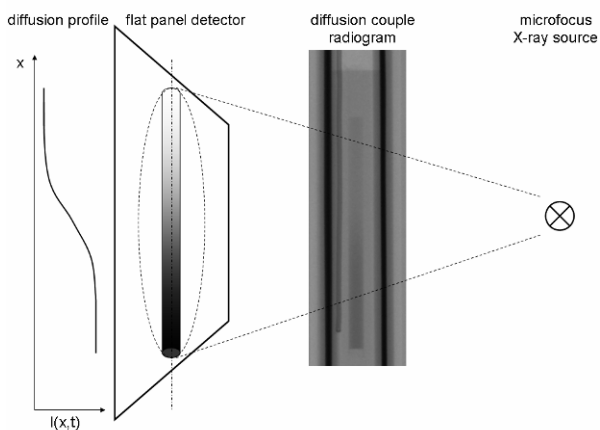

Representation of an X-ray of a metal sample (Image: DLR)

Studies of diffusion processes in liquid metals in weightlessness have been carried out before. However the novel feature of the MAXUS-8 experiment is to visualise the process live and in-situ for the first time. Using a special X-ray set-up will allow researchers to “look” inside the liquid metal, since metals and semiconductors absorb X-rays in a way which is uniquely dependent on their atomic number. This will allow for observation of the melt’s concentration profile over time and enable the direct measurement of diffusion coefficients with very high accuracy. Alloys of aluminium/aluminium-copper, aluminium/aluminium-nickel, and silicon/germanium will be studied, which are of major relevance to industry, being widely used in automotive engines, jet engine turbines and solar panel arrays respectively.



Photovoltaic solar panels (Image: Enel Green Power S.p.A.)

Science Team: A. Griesche, BAM Berlin, Germany; F. Kargl, DLR Cologne, Germany; R. Mathiesen, Norwegian University of Science and Technology, Trondheim, Norway

Biology Research

Cytoskeletal forces underlying gravity sensing mechanisms of Characin cell structures

The aim of this biology experiment is to extend earlier studies by the science team aimed at understanding the mechanisms of cell structures to perceive gravity in both intensity and direction in the model Characean algae (common names: stonewort or muskgrass). The cell structures being studied are the rhizoids (root like structures) which grow downwards to anchor into lake sediment, and the protonemata which grow upwards towards light and are responsible for division and regeneration.



A snapshot of the video feed, showing the "statoliths" displaced at the plasma membrane of the cell
(Image: EADS-Astrium)

Data from a previous sounding rocket experiment indicated that lateral accelerations between 0.05g and 0.14g are required to displace "statoliths" (intracellular sediment particles) towards the gravity sensitive plasma membrane site, where contact of statoliths with gravi-receptors induces cell-type specific responses.

It is believed that the cell cytoskeleton, i.e. the cell's structural support, is involved in the gravity sensing process and this experiment will perform a comprehensive analysis of molecular cytoskeleton forces. Rhizoids and protonemata

will be installed onto a rotating platform inside of the MAXUS-8 experiment module permitting centrifugal accelerations to be applied to the cells stepwise from 0.05g to 0.09g for 60s each. This will follow an initial adaptation time of about 5 minutes.

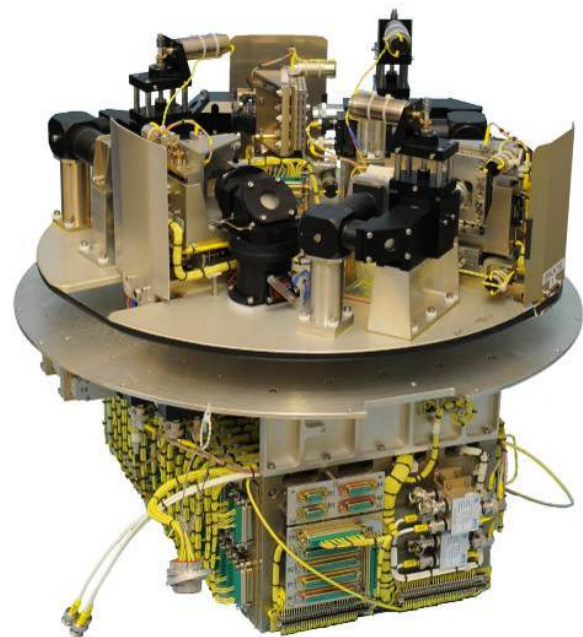

The experiment module with the three microscopes and cell set-ups installed on its rotating platform (photo credit: EADS-ASTRIUM)

Data from this study will refine the gravi-sensitivity mechanism, which is solely dependent upon cytoskeletal force. The experiment will provide for accurate estimates of the number of contacts per time unit between cytoskeleton elements and individual "statoliths".

This data will allow scientist to determine the energy required for each physical step and the first physiological process, or perception, of gravi-tropic pathways, that are preferred directions that cells choose in function of their perception of gravity. In summary this experiment may produce results which complete the molecular based picture of gravity sensing in plant cells.

Science Team: M. Braun, B. Buchen, N. Vagt
University of Bonn, Germany.

Technology Demonstrations

SHARK

Further to its programme of experiments in weightlessness, MAXUS-8 will also deploy and drop a secondary capsule that will separate from the payload during ascent at an approximate altitude of 150km. The SHARK (Sounding Hypersonic Atmospheric Re-entry Kapsule) project, supported by ESA's Technical Directorate, consists of a fully autonomous system aimed at proving the feasibility of dropping a "black-box" from outside the Earth's atmosphere as part of a former space object (e.g., a rocket booster).

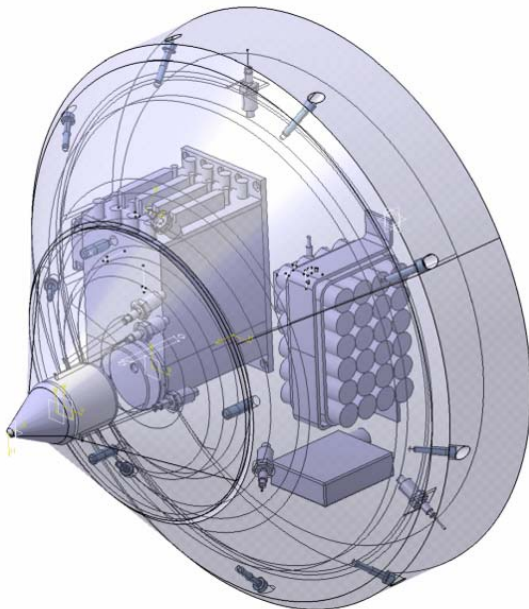

A schematic drawing of SHARK, showing its internal subsystems (Image: CIRA)

Supersonic regimes, crash loads and recovery in a hostile terrain where the capsule might land, represent its technical and operational challenges. SHARK (taking the place of what would otherwise be mass ballast needed for stability reasons) is attached to the re-entry aft cone and enclosed within the inter-stage adapter of the MAXUS-8 rocket by means of a dedicated interface and a separation mechanism. Its deployment will occur shortly after the end of the motor thrust phase.

The Italian company CIRA (Centro Italiano Ricerche Aerospaziali) volunteered to produce at the SHARK hardware its own cost.

The Value of Sounding Rockets

A Sound Investment

With the MAXUS-8 mission, ESA continues its leading role in maintaining autonomous European microgravity platforms able to offer the user community with frequent flight opportunities in addition to the utilisation of the International Space Station (ISS).

Sounding rockets provide scientists with an invaluable opportunity to perform experiments that would otherwise not be feasible onboard the ISS due to safety constraints, the lack of access to experiment racks and laboratories, relevant design limitations, and to the stringent need for continuous and interactive control of the experiment from ground. The relatively quick turnaround of results from sounding rockets also makes them extremely compatible with industrial timescales for research and development purposes.

In addition, sounding rocket flights have become more and more attractive to prepare ISS experiments, for in-flight testing of new instrumentation and diagnostic tools prior to their implementation on board the ISS, and, last but not least, to meet with the requirements of self-standing scientific investigations that do not require a long exposure time to weightlessness.

While taking the full benefit of long term investments and of the significant and specific experience built up by relevant industries, ESA is engaged at involving small and medium-size enterprises from different member states in development tasks for the MAXUS modules and subsystems. Along with this, ESA continues to improve this valuable platform by gradually introducing more advanced/efficient subsystems.

* The IMPRESS project is funded under EC Contract # NMP3-CT-2004-500635

Credits

This document has been compiled, produced and written by the Coordination Office and the Utilisation Department of the European Space Agency's Directorate of Human Spaceflight in Noordwijk, The Netherlands. It has been compiled from internal ESA sources with additional images and information kindly supplied by the following organisations:

EADS Astrium

Swedish Space Corporation (SSC)

German Aerospace Center (DLR)

Contacts

European Space Agency (ESA)

Directorate of Human Spaceflight
ESTEC, Keplerlaan 1, PO Box 299
2200 AG Noordwijk, The Netherlands.
Tel: +31 (0) 71 565 6799
Fax: +31 (0) 71 565 5441
www.esa.int/spaceflight

ESA Media Relations
ESA Head Office, Paris, France.
Tel. + 33 1 5369 7155
Fax. + 33 1 5369 7690
contactesa@esa.int

InterMetallic Processing in Relation to Earth and
Space Solidification (IMPRESS)
www.spaceflight.esa.int/impress

EADS Astrium

<http://www.astrium.eads.net/>

Swedish Space Corporation (SSC)

<http://www.ssc.se/>

German Aerospace Center (DLR)

<http://www.dlr.de/en/desktopdefault.aspx>