

# Overview of ISS science experiments definition, integration and implementation



*Eric Istasse*

ESA Mission Science Office  
Science and Applications Division  
*ISS Utilisation Department*

*Directorate of Human Spaceflight, ESA.*



## Agenda

- Implementation of science experiments as part of the ESA research program in the Human Spaceflight Directorate;
- Focus on ISS: planning and manifesting processes;
- Some examples of successful Columbus experiments to date.



- ✓ Implementation of science experiments as part of the ESA research program in the Human Spaceflight Directorate;
- Focus on ISS: planning and manifesting processes;
- Some examples of successful Columbus experiments to date.

## Implementation of science experiments in the Human Spaceflight Directorate

- The main ESA Human Spaceflight Directorate science programme is called “ELIPS” (European Life and Physical sciences programme in Space);
  - The programme is based on a multi-disciplinary / multi-user / multi-platform approach;
  - ESA has developed a strong position in the non-military space environment, providing multiple assets to enable good science implementation to a broad and increasing science community;
- How to get to in-flight execution from the initial science project submittal ?

## From a scientist's point of view: "how to get there?": the access to European research in space...

- ESA organises the access to all experimental platforms (incl. ISS) via the publication of Announcements of Opportunity (AO):
  - ◆ Regularly advertised AO for major platforms (ISS, Foton capsules, Sounding rockets)
  - ◆ Continuous AO for "easy access" platforms (Parabolic flights, Drop Towers, Ground-based Facilities)
- There exist calls for International AOs and for Domestic AOs;
- ESA also organises Call for Ideas prior to AOs.

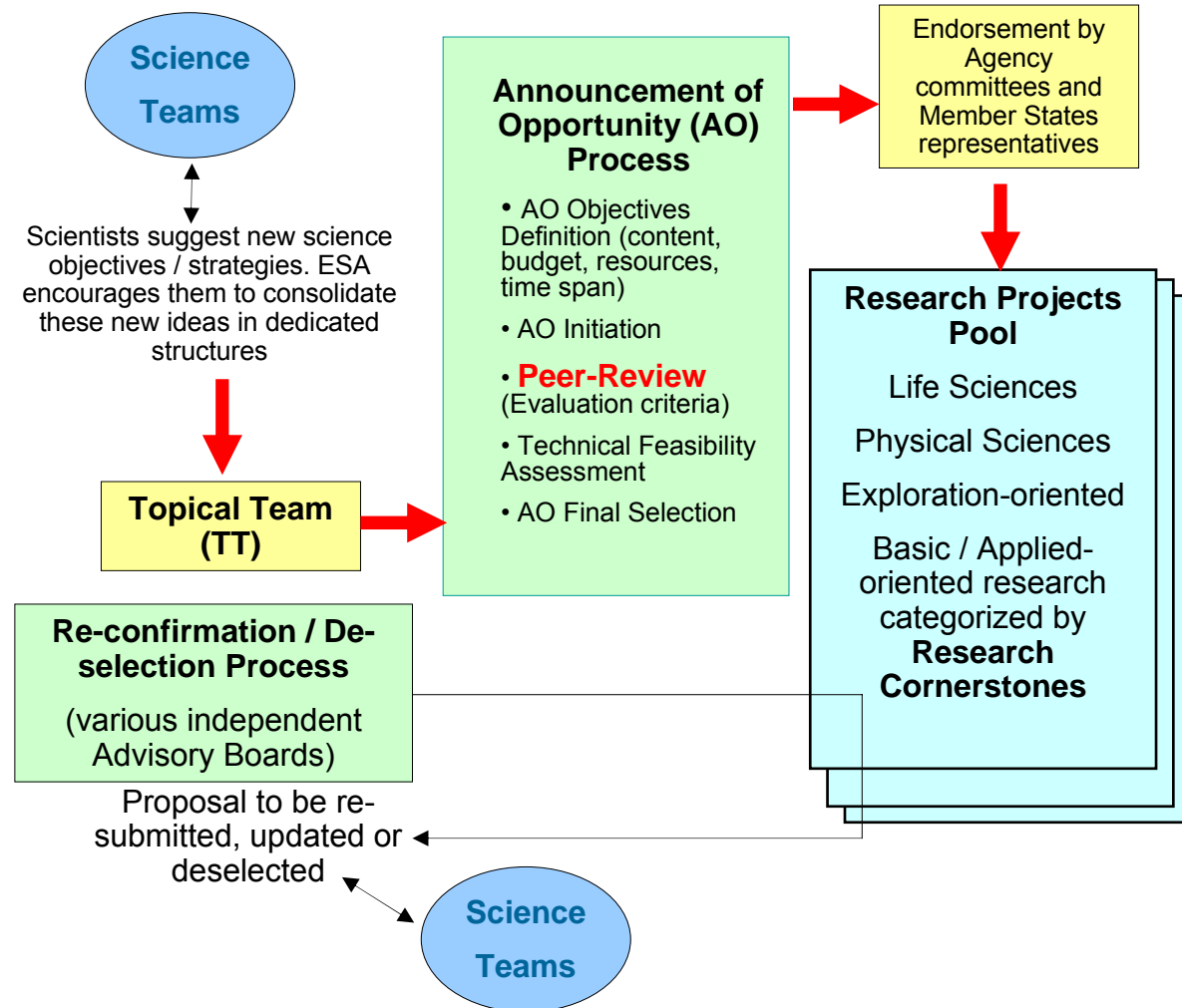



# From a scientist's point of view: "how to get there?": after the peer-review selection...

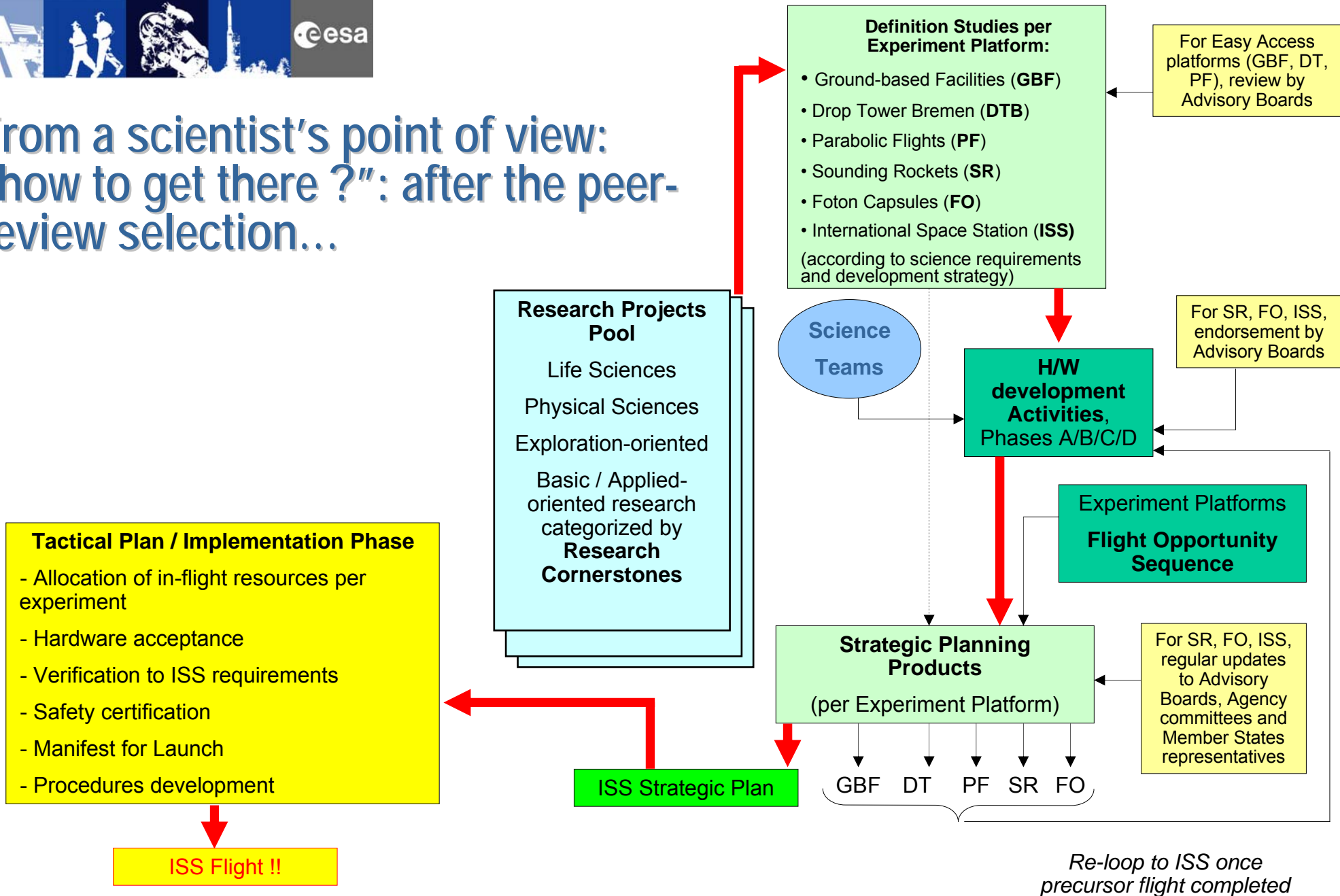



- Implementation of science experiments as part of the ESA research program in the Human Spaceflight Directorate;
- ✓ Focus on ISS: planning and manifesting processes;
- Some examples of successful Columbus experiments to date.



For current baseline refer to SSP 54100 IDRD Flight Program

# Flight Program Working Group (FPWG)

## Crew Rotation and Port Utilization Graphic – For Reference Only

NASA Official: Sean Fuller  
Prepared by: Scott Paul  
Chart Updated: October 27, 2009  
SSC/CR: 012008

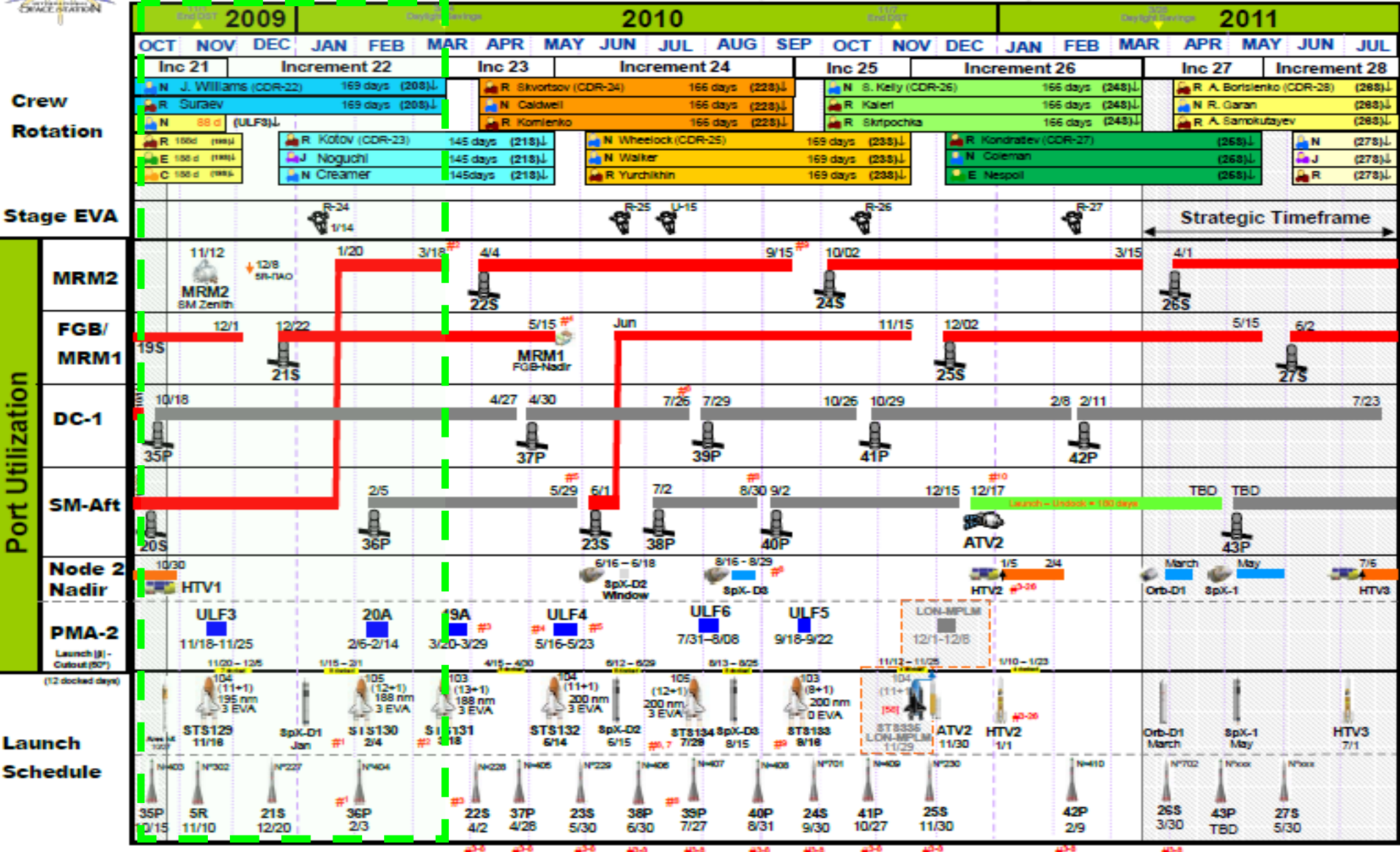

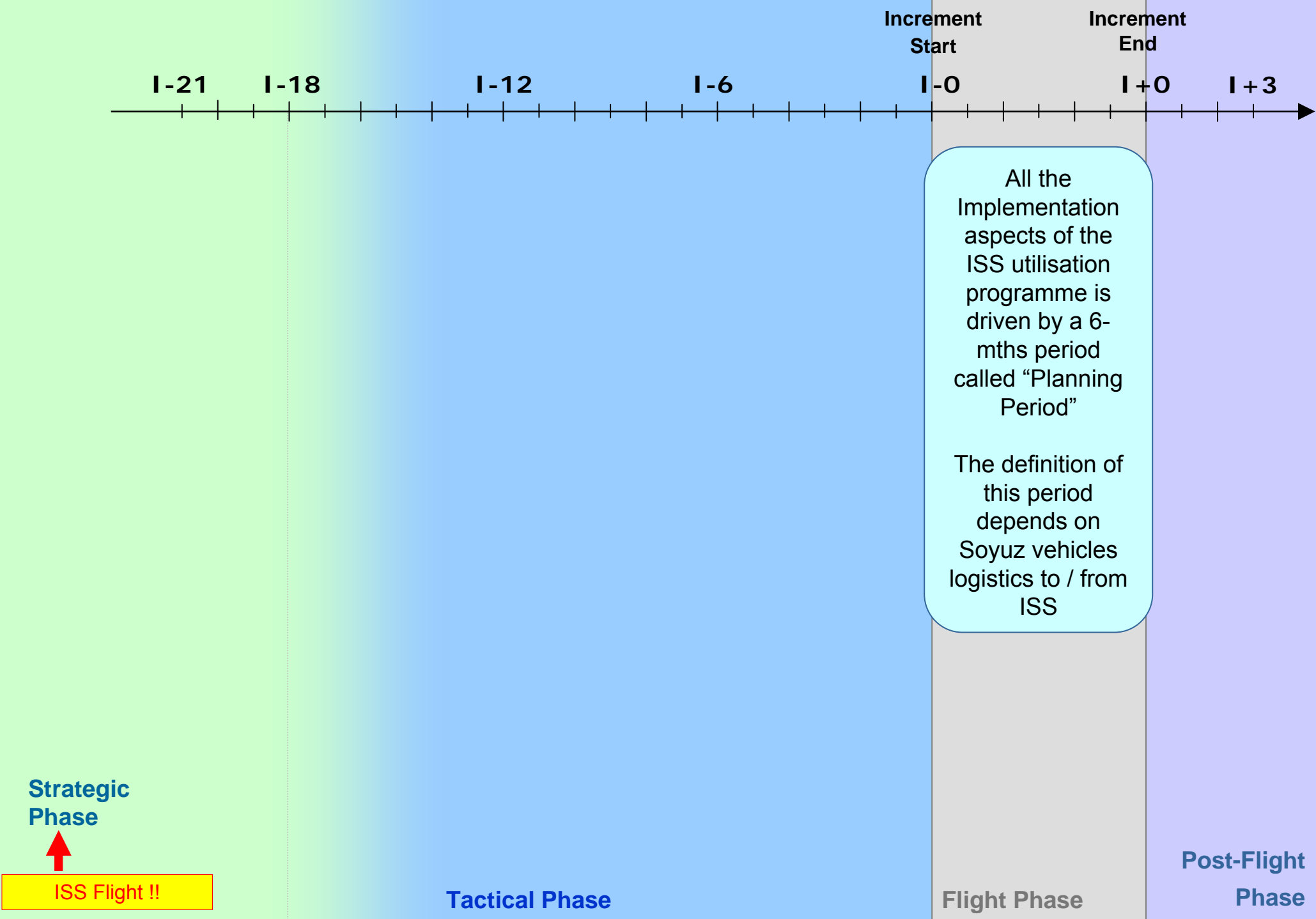

I-21

I-18

I-12

I-6

I-0

I+0

I+3

Increment  
Start

Increment  
End

All the Implementation aspects of the ISS utilisation programme is driven by a 6-mths period called "Planning Period"

The definition of this period depends on Soyuz vehicles logistics to / from ISS

Strategic  
Phase



ISS Flight !!

Tactical Phase

Flight Phase

Post-Flight  
Phase

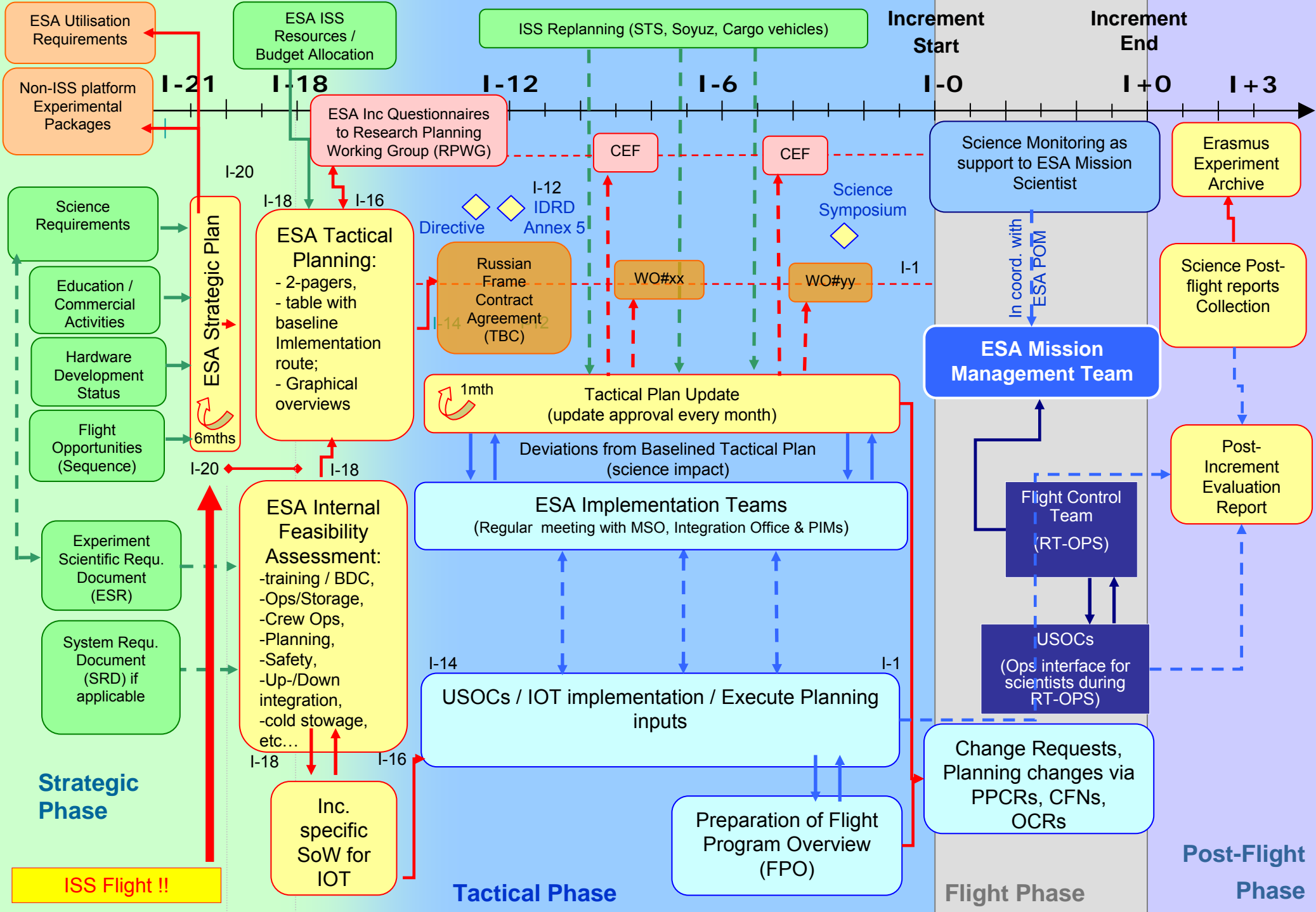

## ISS Operations Setup

- International environment: MCC-H, POIC and MCC-M + COL-CC;
- 24/7 follow-up and planning;
- Coordination not only around the clock, but around the world !
- Telemetry and telecommanding;
- KU-Band and S-Band;
- Partial ISS satellite coverage...

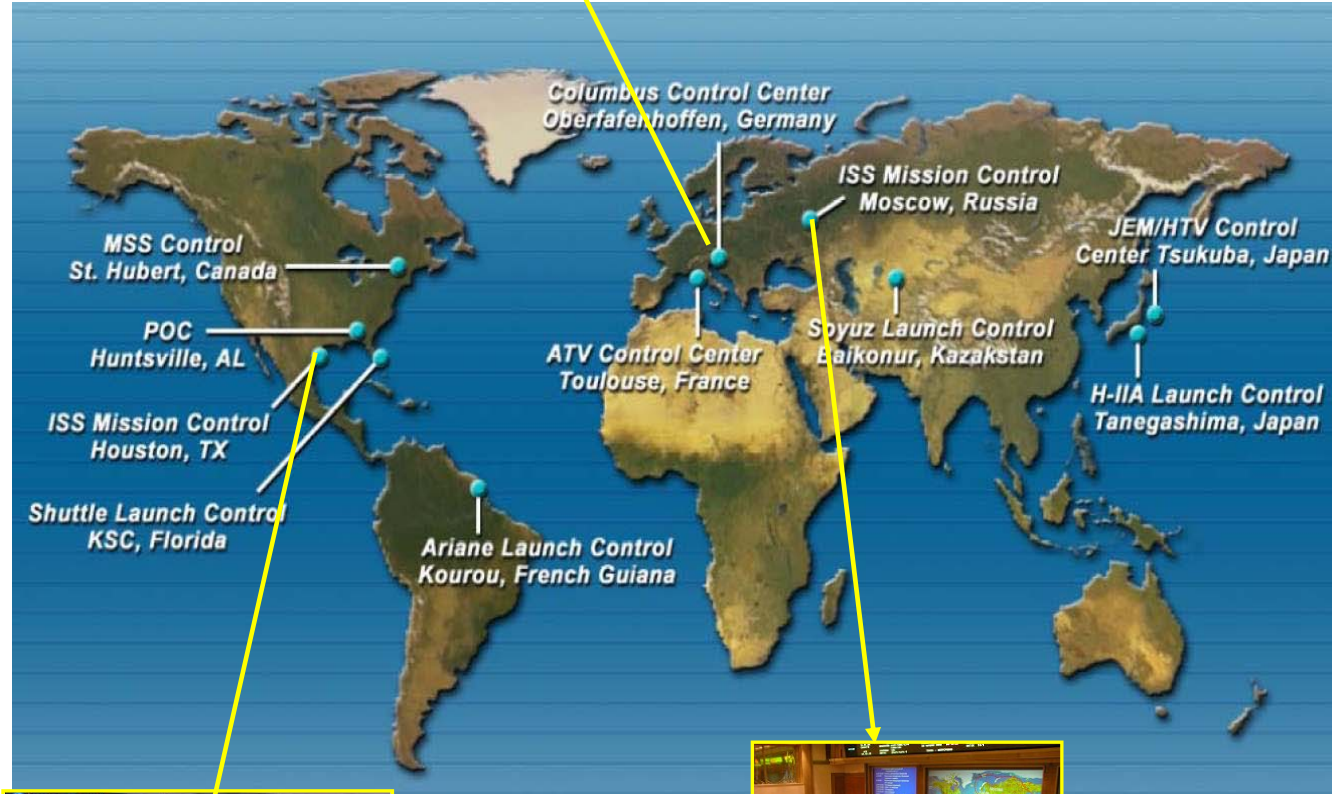

## ISS Operations Setup: Ground Segment network

Summary of overall ISS data transmission capabilities (ESA has rights to 8.3% of overall data)

Data Transmission System	Data Rates
Command uplink rate (S-band)	High Data Rate: 72kb/s Low Data Rate: 6kb/s Columbus module allocation: 10-36kbps
Command downlink rate (S-band)	High Data Rate: 192kb/s Low Data Rate: 12kb/s Columbus module allocation: 15-60kb/s
Data/Video Downlink (Ku-band)	Up to 100Mb/s available for utilisation (rates may vary from 2.8 to 95Mb/s) Columbus module: up to 43Mb/s (actual allocation determined in planning, can vary from 0-43Mb/s)

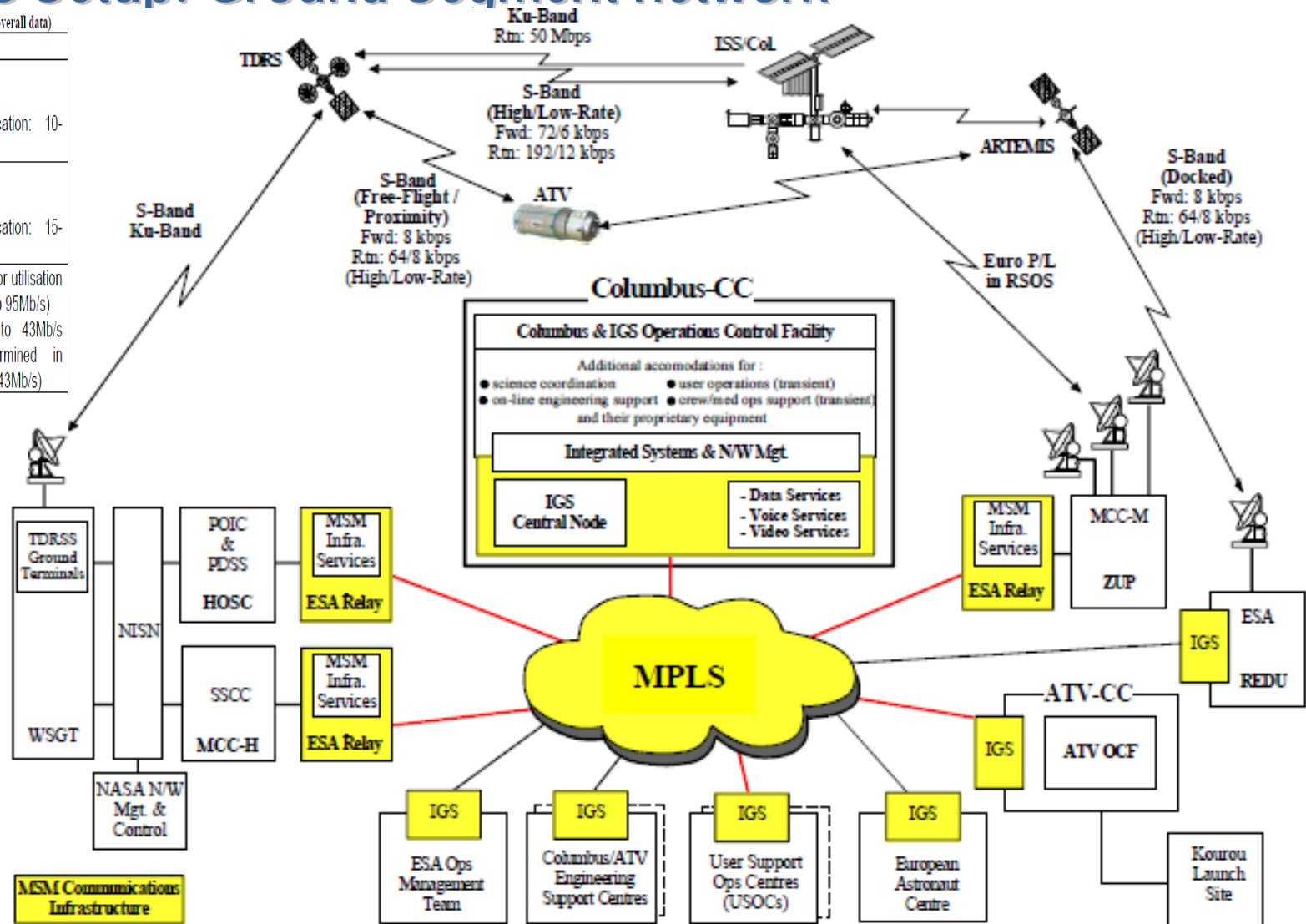

Interconnection Ground Subnetwork (IGS)

Multiprotocol Label Switching (MPLS)

## "Increment-based" ISS Operations, up to astronaut daily timeline...

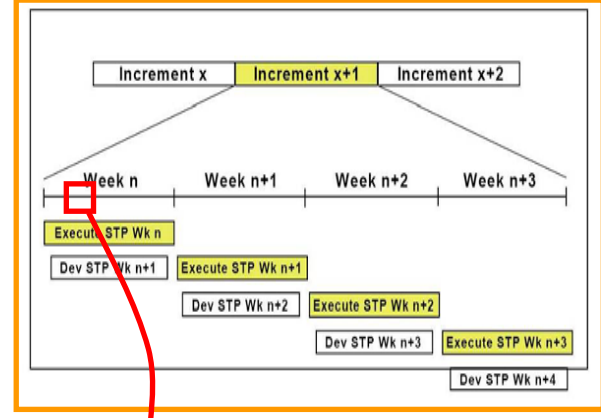
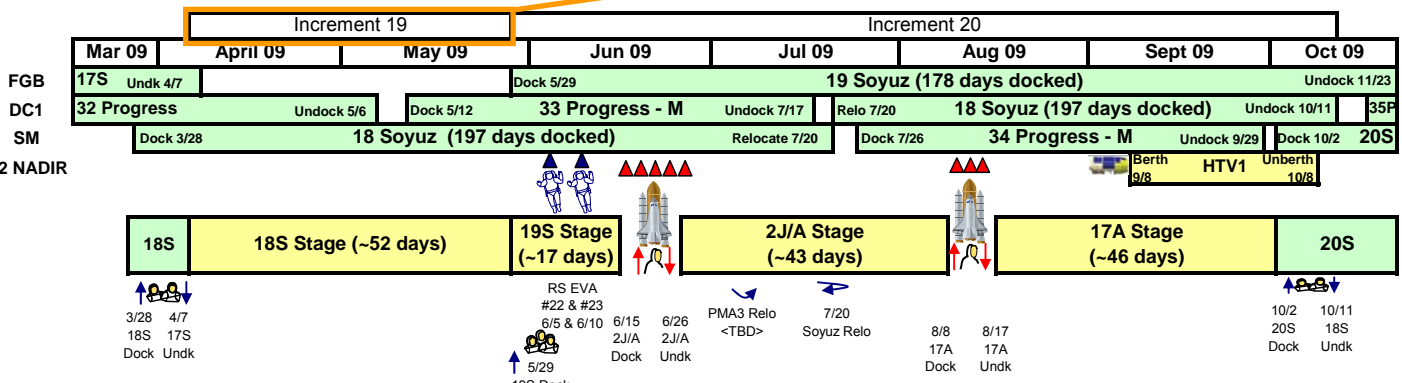

Page 14

Secure web-based tools (partly shared with on-board crew members)

## Typical aspects to be worked out during Tactical Plan / Implementation Phase

- Check hardware w.r.t.:
  - ◆ Design compatibility with ISS environment and vehicle logistics;
  - ◆ Readiness for a given launch date;
  - ◆ NASA / ESA / RSC-E safety reviews (incremental);
  - ◆ Documentation preparation;
  - ◆ Acceptance reviews;
- Depending on the need for an astronaut to support the experiment:
  - ◆ As test subject:
    - Medical Boards approval
    - Informed Consent Briefing processes
    - Baseline Data Collection
    - Procedures Training;
  - ◆ As operator:
    - Procedures Training;

## Typical aspects to be worked out during Tactical Plan / Implementation Phase

- International negotiation of the resources:
  - ◆ Upmass / in-flight / downmass;
  - ◆ Allocation of telemetry / telecommanding data bandwidth;
  - ◆ Specific agreements to use USOS / Russian equipments and/or facilities;
  
- Make sure that your experiment is being integrated in consolidated plans for:
  - ◆ Baseline Data Collection (if applicable);
  - ◆ Cold Stowage (if applicable);
  - ◆ Vehicle manifests;
  - ◆ Stage analysis (i.e. power, on-orbit gas consumables budgets);
  - ◆ Ground transport logistics (e.g. customs);
  - ◆ Operation products (e.g. planning of activities and related procedures).



- Implementation of science experiments as part of the ESA research program in the Human Spaceflight Directorate;
- Focus on ISS: planning and manifesting processes;
- ✓ Some examples of successful Columbus experiments to date.

## Examples of Utilisation achievements with ESA External Platforms

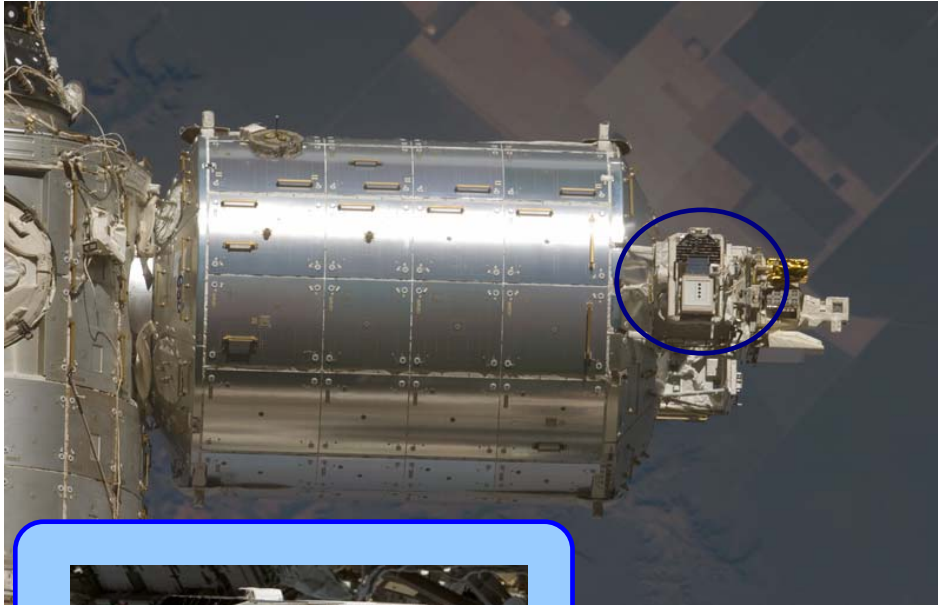

**SOLAR**  
(3 experiments)

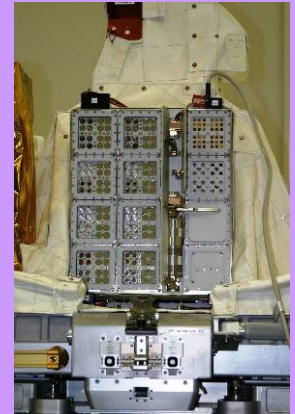
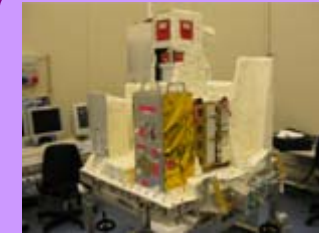

**EuTEF**  
(9 experiments)



## Utilisation achievements: SOLAR platform

- Continuous science acquisition with 2 out of 3 instruments, for periods of ~10days every month (depending on beta angle conditions, i.e.  $-24\text{deg} \leq \beta \leq +24\text{deg}$ );
- Outstanding results with SOLACES and SOLSPEC instruments, under a cooperative effort with NASA measurements during sounding rocket campaigns;
- Positive technical assessment to plan for a SOLAR mission extension beyond 19A (STS-131) and at least up to end 2013.



SOLAR  
(3 experiments)



SOLSPEC



SOLACES



SOVIM

# Utilisation achievements: EuTEF platform

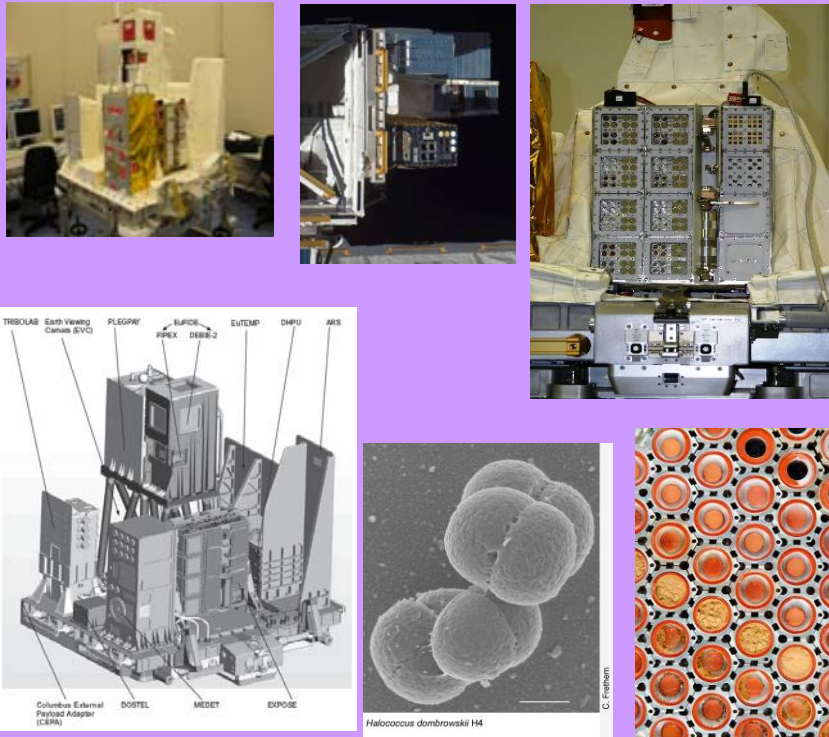

**EuTEF**  
**(9 experiments)**

- Continuous science acquisition for technology / physical / debris / radiation / exobiology research;
- Large set of exobiology samples for 5 experiments in the trays of the EXPOSE-E instrument;
- Nominal science acquisition for DOSTEL, FIPEX instruments. Minor glitches for DEBIE-2, EVC and TRIBOLAB experiments;
- Successful return of the whole EuTEF platform on 17A (STS-128). Now the post-flight analysis is starting...



**Thank you for your attention...**