



Experimenter Specification and Users manual

Document No
LDC-ESUM 21082009/JK+AD

Author of this document:

Jutta Krause, Alan Dowson in co-operation with Zeugma
Tecnologia de Sistemas Industriais SA,

Document No LDC-ESUM 21082009/JK+AD	Experimenter Specification and Users manual	Revision 21-08-2009	Page ii
---	--	------------------------	------------

List of Abbreviations

AC – Alternate current

CAD – Computer Aided Design

CAN - Controller Area Network Protocol

CCTV - Closed-Circuit Television

CFD – Computational Fluid Dynamics

CG – Centre of Gravity

ESA – European Space Agency

FEA – Finite Element Analysis

GCC - General control Cabinet

HMI – Human Machine Interface

I/O – Input/Output

LAN – Local Area Network

LDC – Large Diameter Centrifuge

PAC – Programmable Automation Controller

PC – Personal Computer

USB – Universal Serial Bus

UPS - Uninterruptible Power Supply

Document No LDC-ESUM 21082009/JK+AD	Experimenter Specification and Users manual	Revision 21-08-2009	Page iii
---	--	------------------------	-------------

Table of Contents

List of Abbreviations	ii
Table of Contents	iii
1 Introduction.....	1
2 LDC system description	1
2.1 Centrifuge structure.....	2
2.1.1 Carry hub	2
2.1.2 Hub	2
2.1.3 Rotor arms	2
2.2 Gondola (Experiment holding facility)	3
2.3 Operation Control Electronics	3
2.4 Science operation bench	6
3 LDC Operation	6
3.1 Operation Control Station	6
4 Scientific Experiments Setup	7
4.1 Introduction	7
4.1.1 Artificial Gravity	7
4.1.2 Experiments Gravity	9
4.2 Scientific Operation Bench.....	10
4.3 Experiment Control Equipment.....	10
4.4 Accessing LDC Data.....	11
4.4.1 LDC System Network Shared Variables.....	11
4.4.2 LDC experimental data	11
5 Gondolas	12
5.1 Gondola description and payload	12
5.2 Gondola placement.....	14
5.3 Gondola Gas and Water supply.....	16
5.4 Gas and Water Bottle Cage	18

Document No LDC-ESUM 21082009/JK+AD	Experimenter Specification and Users manual	Revision 21-08-2009	Page iv
---	--	------------------------	------------

5.5	Gondola Electrical Connections.....	19
5.5.1	Gondola USB connection	19
5.5.2	Gondola Serial (RS 232) connection	20
5.5.3	Video connection	20
5.5.4	Ethernet connection.....	21
6	LDC constrains and safety	21
6.1	LDC constrains.....	21
6.2	LDC safety	22
7	Available instrumentation	22
8	LabView.....	22

Document No LDC-ESUM 21082009/JK+AD	Experimenter Specification and Users manual	Revision 21-08-2009	Page 1
---	--	------------------------	-----------

1 Introduction

This manual is written to enable experimenters and their teams to prepare the experiments they plan to perform on the Large Diameter Centrifuge (LDC). This document gives the technical specification of the LDC and its components as well as a description of the operational part of the LDC. It is to notify already at this point that the LDC however is only operated by trained laboratory personnel only.

The LDC is flexible in terms of experiment scenarios definition and possible equipment to use. This means that the system is able to define, execute and manage as well short duration experiments of, for example 1 minute up to long duration experiments up to 6 months without maintenance of the LDC. Via the operation station it is as well possible to change or redefine the experiment profile if required.

2 LDC system description

The LDC consists of the following subsystems

- Centrifuge structure
- Operation control electronics
- Bottle Cage
- Gondola for Control experiment
- Gondola (Experiment holding facility)



Fig. 2.0 LDC

- Operation control station, located in the control room
- Science operation bench, located in the control room

Document No LDC-ESUM 21082009/JK+AD	Experimenter Specification and Users manual	Revision 21-08-2009	Page 2
---	--	------------------------	-----------

2.1 Centrifuge structure

The centrifuge structure is the centre of the system and includes:

- The carry hub with the connection to the floor and the central bearing and structural assembly.
- The hub
- Four rotor arms

2.1.1 Carry hub

The carry hub incorporates the central axis of rotation for the system and includes:

- The central axis bearings
- Motor and gear unit
- Disk brakes
- Slip ring for signal and power transfer
- Encoder for speed/position measuring
- Vibration sensor
- The structural assembly for holding the hub

2.1.2 Hub

The hub includes:

- Holding/mounting/assembly structure of the four rotor arms
- Central gondola for control experiment
- Central PC for monitoring and routing (from gondolas)
- Mounting facility for up to eight 50l gas/water bottles (four in each side)
- Mechanical and electrical interfaces for scientific and monitoring instrumentation
- The data acquisition and sensors (temperature, accelerometers, proximity switches)
- A PAC (programmable automation control) to receive and process housekeeping and monitoring data from equipment at centrifuge rotation section
- An Ethernet switch to create a link between all equipment at centrifuge rotating section and equipment at control room, through slip ring assembly

2.1.3 Rotor arms

- Holding/mounting points for the gondolas
- Interfaces connectors (electrical, air, gas and water) for the gondolas
- Centrifuge monitoring sensor (to detect the mounting position of gondolas) hardwired to PAC at hub

Document No LDC-ESUM 21082009/JK+AD	Experimenter Specification and Users manual	Revision 21-08-2009	Page 3
---	--	------------------------	-----------

2.2 Gondola (Experiment holding facility)

The subsystem is the interface to the scientific experiment, attached to the rotor and will consist of:

- The gondola housing with swing shaft for arms positioning
- The scientific data interfaces (Serial, USB, Ethernet, Video)
- The scientific medium interfaces (Air inlet and outlet, gas and water connectors)
- The gondolas sensors (temperature and accelerometers)

2.3 Operation Control Electronics

The control electronics is composed of all components required to achieve the specified functions and consist of (see Figure 2.1):

- Power supplies and circuit breakers
- The safety control and interlock system
- One PAC (programmable automation control) to receive and process housekeeping and monitoring data from equipment placed on centrifuge structure, centrifuge room and control room
- Ethernet switch to create the communication link the control components
- AC drive to control the motor velocity at carry hub

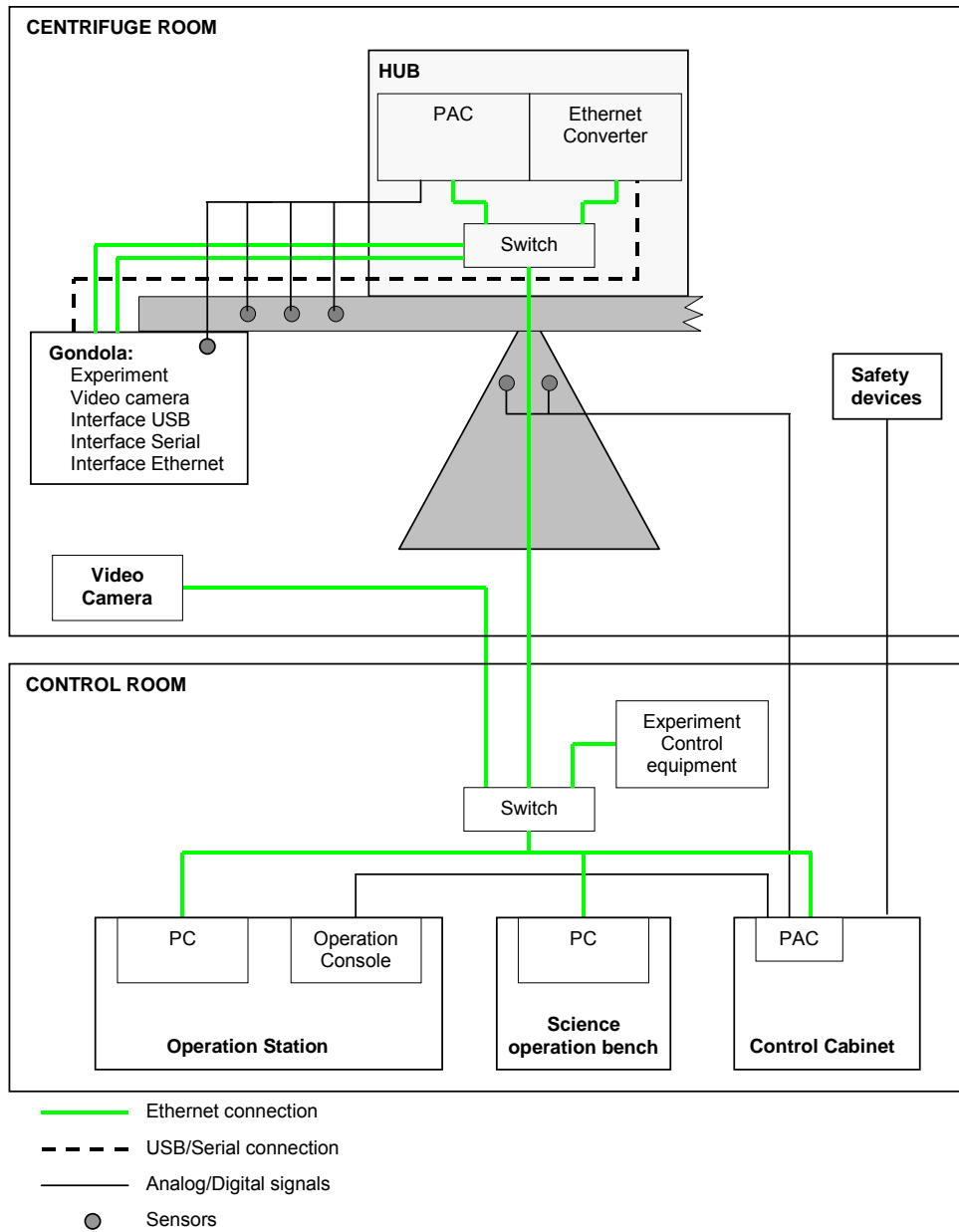

Figure 2.1 – Operation Electronics Scheme

With the infrastructure described data exchange between the several subsystems:

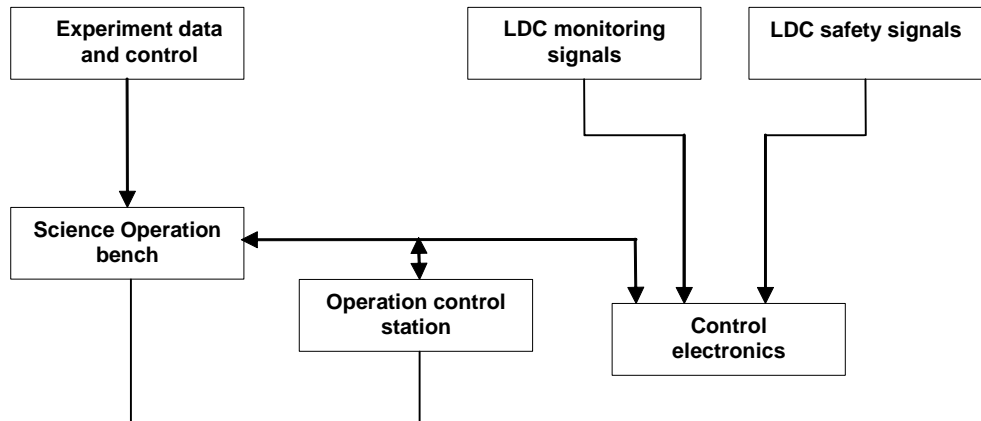

Figure 2.2 – Operation Data Flow Scheme

- a. Control electronics:
 - Receive and process the signals to control and monitor the LDC;
 - Provide data about the current status of LDC to operation control station;
 - Receive data from operation control station.
- b. Operation control station:
 - Exchange data with control electronics;
 - Exchange operational data with science operation station;
 - Housekeeping
- c. Science operation bench
 - Receive, store and process all experiment data received from gondolas;
 - Exchange operational data with operation control station
 - Provide access to scientific data to remote users through internet.

2.4 Science operation bench

The Scientific station is comprised of a workstation computer and the video panel.

The workstation is setup for the scientist development and running of LabView software. The scientist software has the ability to acquire all the scientific and housekeeping data of the experiments. This data are received via the operation control station.

3 LDC Operation

3.1 Operation Control Station

Operation of the LDC is carried out at the Operation Control Station, which consists on a workstation PC and an operation panel with command push buttons.



Figure 3.1 – Operation Control Station

The PC is connected to Ethernet network and runs a LabView HMI application with the following functionalities:

- a. Shows actual LDC status based on monitoring data got from PAC at hub and PAC at control room;
- b. Record the monitoring data from PAC at hub and PAC at control room;
- c. Provide to operator interfaces to select and display;

Document No LDC-ESUM 21082009/JK+AD	Experimenter Specification and Users manual	Revision 21-08-2009	Page 7
---	--	------------------------	-----------

- d. Provide to operator interfaces for changing the operating mode, and operational scenarios;
- e. Manage the control set points to be sent to PAC at control room, based on actual operation scenario;
- f. Manage the maintenance related functions: Maintenance intervals; maintenance log book;
- g. Manage users logging: Logging authorisation, operators log book;
- h. Provide housekeeping data access to users on remote workstations via Ethernet and Internet.

The operation panel contain:

- a. Two independent devices (push buttons) to start and stop the rotation;
- b. A stop button for motor braking and standard slowdown;
- c. An emergency stop button to actuate the electromagnetic brakes and instant stop (below 30 sec).

4 Scientific Experiments Setup

4.1 Introduction

For the scientific understanding and description of the influence of gravity in living systems, the observation of behaviour at the two points “micro (zero) gravity” and “1-g” is not sufficient. To complete the image, observation of all types of specimen has to be exposed to a variety of accelerations values below and above 1-g (hyper gravity). Typical specimen sizes range from cells and micro organisms to small animals and human beings. A large diameter centrifuge can provide the hyper gravity environment to cells and small animals, allowing the acquisition of the measurement points in the range from 1 to 20-g. The application of such an instrument is not limited to living systems, but may have also applications in the area of Physical Science experiments.

4.1.1 Artificial Gravity

The Large Diameter Centrifuge system is used for experimental hyper gravity setups. The system comprehends a large rotating arm where a swing gondola is attached at the extremity. The rotational movement of the arm and gondola creates an artificial acceleration field at the equipment positioned inside the gondola. The LDC represents a rotational reference frame and in these cases the Coriolis forces are present and must be taken into account.

The equipment acceleration, \vec{a}_{eq} , is given by

$$\vec{a}_{eq} = \vec{a}_{centripetal} + \vec{a}_{Coriolis} + \vec{a} + \vec{g}$$

Where

\vec{a} - Relative acceleration of objects inside gondola (due to motion in gondola)

$\vec{a}_{centripetal}$ - Centripetal acceleration (from rotation)

$\vec{a}_{Coriolis}$ - Coriolis acceleration

\vec{g} - Gravity acceleration (vertical direction)

The LDC study goal is to design the system in order for the centripetal acceleration become our design acceleration and simultaneously minimizing the Coriolis acceleration, since the general acceleration is experiment dependent and out of control for the LDC study.

The $\vec{a}_{centripetal}$ is the radial direction acceleration given by

$$\vec{a}_{centripetal} = \vec{\omega} \times \vec{\omega} \times \vec{r}$$

where ω is the LDC rotational speed (rad/s) vector and r the LDC gondola position vector (arm length vector plus the gondola length vector). See Figure 1.1.

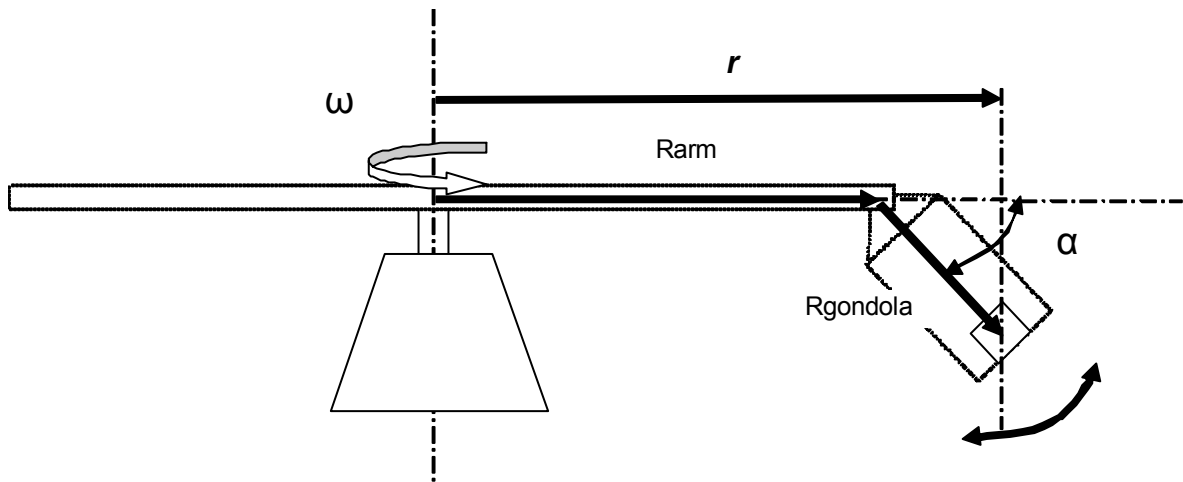

Figure 4.1 – LDC System position

The Coriolis force, $\vec{a}_{Coriolis}$, is given by

$$\vec{a}_{Coriolis} = 2\vec{\omega} \times \vec{v}$$

where \vec{v} is the object relative velocity in the reference frame (attached to the LDC).

In order to achieve hyper-gravity, the artificial gravity is attainable by high rotational speed and high arm length (ω , r respectively).

Document No LDC-ESUM 21082009/JK+AD	Experimenter Specification and Users manual	Revision 21-08-2009	Page 9
---	--	------------------------	-----------

In order to keep the Coriolis acceleration small, the use of high arms length is desired. The LDC machine has a maximum of 4 m radius distance, which is enough to consider the Coriolis force as a secondary effect, with less then 0.05% perturbation in comparison with the centripetal acceleration produced.

4.1.2 Experiments Gravity

The Large Diameter Centrifuge system is used for experimental hyper gravity setups. The equipment will suffer an artificial acceleration of a_e (experimental acceleration) as a result of the earth gravitational acceleration and the centripetal acceleration developed by the rotating arm speed. See Figure 1.2.

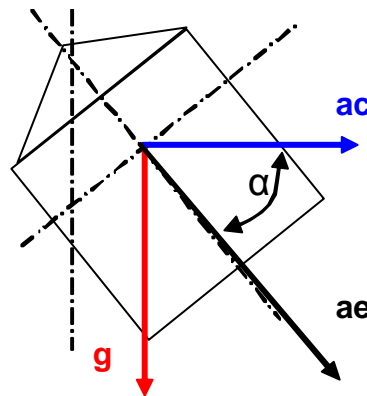

Figure 4.2 – Gondola equipment experimental acceleration.

With the hyper gravity experiments as a goal, the following relation can be made between the centripetal acceleration and the experiment acceleration (equivalent gravity acceleration that the equipment will be subject to), as

$$a_{\text{exp}} = a_{\text{centripetal}} \cos(\alpha)$$

where the gondola rotation angle, α , is given by

$$\text{tg}(\alpha) = \frac{g}{a_{\text{centripetal}}}$$

The gondola angle is related to the arm rotor speed and its evolution with the increase of rotor speed is presented in Figure 4.3 considering an average arm radius of 3.9 m and $g = 9,8 \text{ m/s}^2$.

The gondola angle at maximum acceleration of 20 g is $\alpha = 2,86^\circ$, which represents a variation from the centripetal acceleration of 0.12% more.

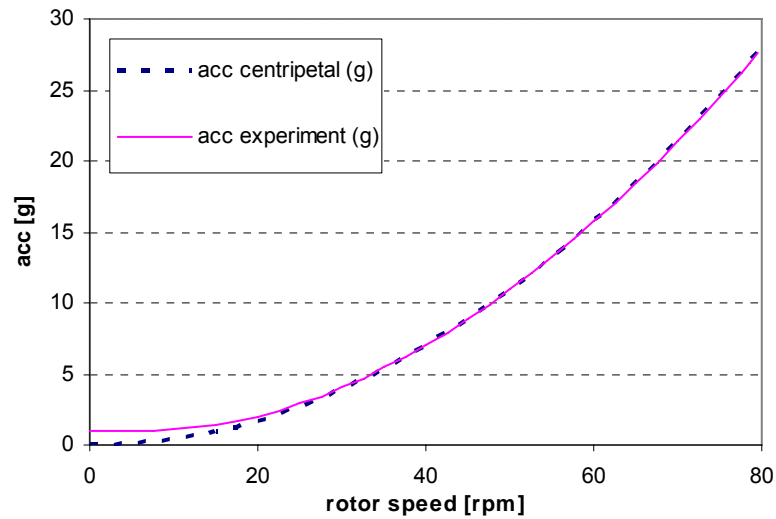

Figure 4.3 – Experimental acceleration variation with rotor speed

4.2 Scientific Operation Bench

Operation of the experiment control equipment and monitoring of experiment is carried out at scientific operation bench. This bench consists on a desktop PC connected to Ethernet network with the following features:

- a. LabView software (developer) for scientists use in the developing applications or running LabView applications for experiments control and monitoring;
- b. LDC monitoring data available, as LabView Shared Variables, (gondolas accelerations and temperature, machine status) to be used on LabView application;
- c. Remote control of the Experiment Control Equipment (desktop PC) in order to control and monitoring the experiment equipments (serial and USB devices) and data routing;
- d. Ability to send automatic experiment specific alarms to the LDC control system. The LDC control system can send SMS/email messages to specific personnel;
- e. Possibility for remote access to users on remote workstations via Ethernet and Internet (under ESA security approval).

4.3 Experiment Control Equipment

The Experimental Control Equipment is a desktop PC with USB and Serial connections hardwired to the gondolas assembled in the LDC arms and the central gondola.

Document No LDC-ESUM 21082009/JK+AD	Experimenter Specification and Users manual	Revision 21-08-2009	Page 11
---	--	------------------------	------------

The equipment is installed on top of the central gondola on the Experimental control cabinet. Its main purpose is to control the USB and Serial devices installed in the gondolas, collect data and route it to the scientific station or save it in local hard drive.

Main characteristics:

- Windows XP Professional operating system
- 9 USB 2.0 connections (8 for the arms and 1 for central gondola)
- 9 Serial connections (8 for the arms and 1 for central gondola)
- 1 Ethernet connection to the LDC LAN
- LabView run time libraries (for running Labview applications)
- Remote Desktop Access setup

4.4 Accessing LDC Data

In order to have access to the LDC sensors data and the gondolas scientific equipment, the scientists need to develop their own software for control and monitoring.

4.4.1 LDC System Network Shared Variables

The LDC system has available the following system data, at the reported time step interval, to be used by any LabView application by means of Shared Variables selection.

- Gondolas Acceleration (vector from 0 to 7, 0 is gondola 1, 7 is the Central Gondola)
- Gondolas temperature (vector from 0 to 7, 0 is gondola 1, 7 is the Central Gondola)
- Running State
- LDC Stop (to be used to stop the LDC from a scientific experiment condition)

For more information about Shared Variables and how to use it in LabView Projects consult the LabView documentation.

4.4.2 LDC experimental data

Besides the LDC system data, the scientist can use the LDC interface connections to control and receive data from USB, Serial, Ethernet or Video devices located inside the gondolas.

In order to access the USB and Serial devices, the scientist must provide the control software and applications, and install them in the Experimental Control Equipment

Document No LDC-ESUM 21082009/JK+AD	Experimenter Specification and Users manual	Revision 21-08-2009	Page 12
---	--	------------------------	------------

(central computer). This software should be capable of recording data or routing it to the scientific station (depending on the scientist necessity).

5 Gondolas

5.1 Gondola description and payload

- Gondola positions per arm: 8 (20,5 cm apart)
- Max payload per Gondola 80kg
- Gondola free volume 600mmx600mmx800mm (WxDxH)
- Working space inside 500mmx500mmx 750mm approximately
- Door clearance 400mmx600mm (WxH)



GONDOLAS LIMIT OF PAYLOAD IS 80 KG.

- A. The payload should be distributed evenly in the gondola floor, experiments plate or the T Slots available inside.
- B. Lab.-Personnel are in charge of LDC balancing!

The gondola T slots are available for fixation of any equipment, see Figure 5.1 and 5.2, with the following remarks; the values shown should be divided by the gondolas experiment acceleration value (G's):

- Vertical T Slots should be loaded for a maximum force of 12 Kg/G
- Top T slots should be loaded for a maximum force of 39 Kg/G

Ex. For a G=10 g experiment the maximum values, for each fixation point, allowed are

- Vertical: 1.2 Kg
- Top: 3.9 Kg

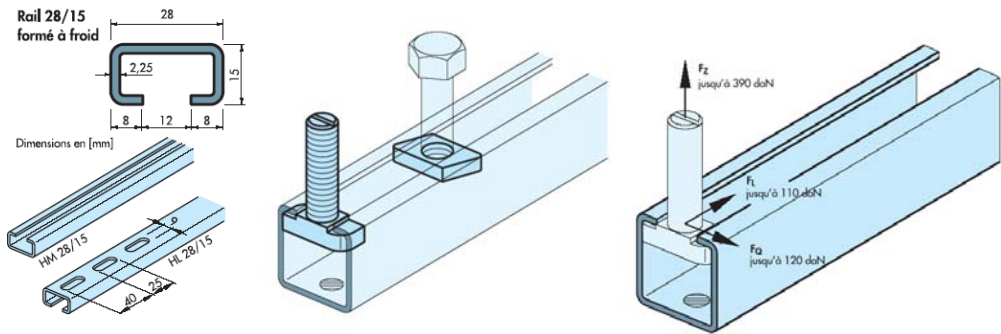

Figure 5.1 – T slot model, fixation options and forces

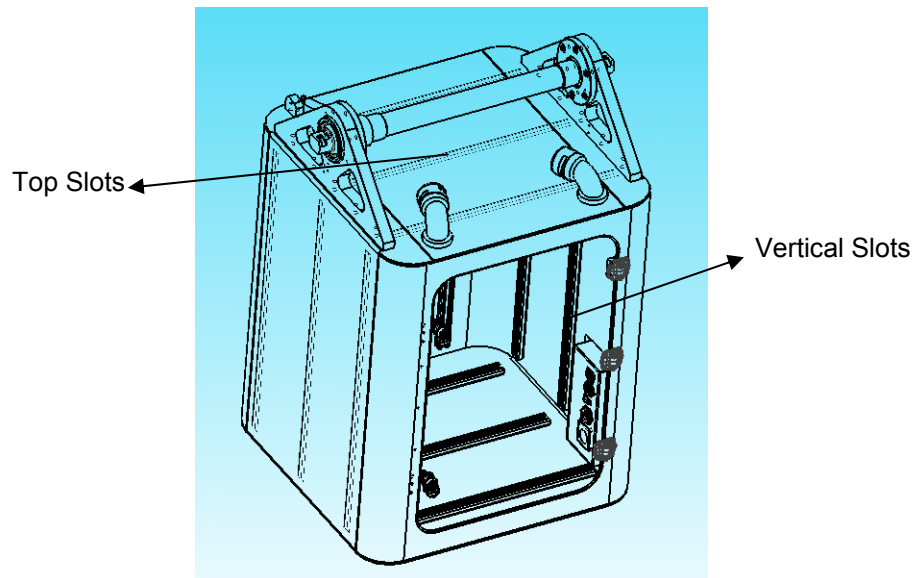

Figure 5.2 – Gondola T slot beams

There are available aluminium plates to be assembled in the gondola floor where it's possible to drill fixing holes and pre-assemble experimental equipment. Bottom Plates can be provided on request.

5.2 Gondola placement



GONDOLA PLACEMENT ON THE LDC IS PERFORMED BY LABORATORY PERSONNEL ONLY.

- C. Laboratory personnel are in charge of gondola placement, connection and the respective safety procedures.

Note that the inner gondolas (max. two of them on a full set up of gondolas on the LDC) will always be placed first.

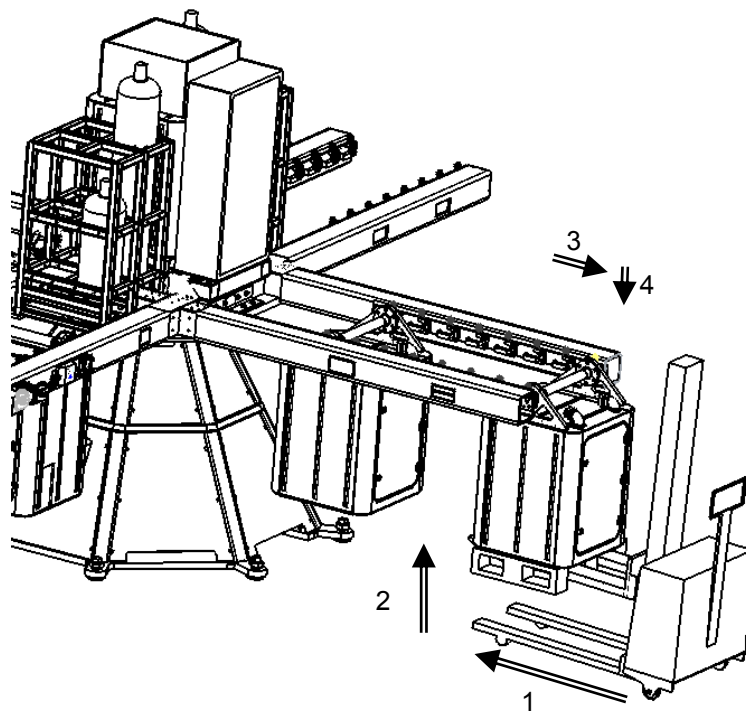

Figure 5.3 – Gondola placement

After the gondola locked in position the laboratory personnel will connect the umbilical cables to the arms and lock the sockets. The air connectors are for inlet and outlet ventilation, and can be connected in any order. The Gas and Water sockets just fit in one of the panel connectors. Pull the tubing and valve from the cable duct for easy coupling of the valves.



Figure 5.4 – Media Sockets connection



Figure 5.5 – Sockets connection

5.3 Gondola Gas and Water supply

The Gondolas have outlets for gas and water supply from bottles that can be mounted in the bottle cage, see Figures 5.6 and 5.6. These bottles must be connected to the plug panel below the central gondola, and this will redirect the media to the gondola outlet.

	<p><u>GONDOLAS TUBING MAXIMUM PRESSURE</u></p> <p>D. For GAS maximum allowed pressure is 6 BAR.</p> <p>E. For WATER maximum allowed pressure is 2 BAR.</p> <p>F. Use tubing with pressure resistance according to experiments.</p>
---	--

Note: Take into account that the water in the tubing will be flowing to the gondolas outlet due to the centrifuge forces when the LDC rotates, which increases the Water pressure at the gondola outlet.

To connect the bottles and equipment to the gas and water outlets use the appropriate tubing size and valve (see table 5.1).

Media	Valve	Tubing
Gas	NS4D17002 (non spill valve from Colder)	3.2mm (1/8") Inside Diameter (maximum) tube
Water	NS6D17006 (non spill valve from Colder)	9.5 mm (3/8") Inside Diameter (maximum) tube

Table 5.1 – Media valve list

The valves body is made of glass-filled polypropylene. Verify Table 5.2 for the chemical compatibility of several chemicals with the valves.

MATERIAL												
CHEMICAL	Polymers					Metals			Elastomers			
	ACETAL	PEEK	POLY-PROPYLENE	POLY-SULFONE	POLY-CARBONATE	CHROME-PLATED BRASS	STAINLESS STEEL (316)	ALUMINUM	BUNA-N (NITRIL)	EPR/EPDM	FLUORO-CARBON (VITON®)	CHEMRAZ® KALREZ®
Acetic Acid	D	A	B	A	B	D	A	B	D	A	D	A
Acetone	A	A	A	D	D	A	A	A	D	A	D	A
Air	A	A	A	A	A	A	A	A	A	A	A	A
Ammonia, Anhydrous	D	A	A	A	D	D	A	A	B	A	D	A
Benzene	A	A	D	D	D	N/A	B	B	D	D	A	A
Carbon Dioxide	A	A	A	N/A	N/A	A	A	B	A	B	B	A
Chlorine Water	D	C	D	B	N/A	D	C	D	D	C	A	N/A
Ethanol (Ethyl Alcohol)	A	A	A	C	B	A	A	B	A	A	A	A
Ethylene Glycol	B	A	A	A	B	A	A	A	A	A	A	A
Gasoline, Unleaded	A	A	C	C	A	A	A	A	B	D	A	A
Hydrochloric Acid	C	A	B	A	D	D	D	D	D	C	A	A
Hydrofluoric Acid	D	C	C	D	D	D	B	D	D	D	B	A
Isopropyl Alcohol	A	A	A	B	A	B	B	B	B	B	B	A
Methyl Ethyl Ketone (MEK)	C	A	B	D	D	A	A	B	D	A	D	A
Methanol (Methyl Alcohol)	A	A	A	C	B	A	A	A	A	A	D	A
Oxygen	A	A	A	A	A	A	A	A	B	A	A	A
Ozone	C	A	B	A	A	N/A	A	B	D	A	A	A
Sodium Hypochlorite	D	A	B	A	N/A	D	N/A	D	C	B	A	A
Steam	C	A	A	A	A	A	A	B	D	A	D	A
Sulfuric Acid, Air-Free	N/A	C	C	D	D	C	B	D	D	D	A	A
Toluene	C	A	C	D	D	A	A	A	D	D	C	A
Trichloroethylene	D	A	C	C	N/A	B	B	D	D	D	A	B
Water, Fresh	A	A	A	A	A	C	A	B	A	A	B	A

KEY

- A = Excellent – no apparent effect
- B = Good – little or no effect
- C = Fair – some effect, not long term
- D = Not recommended, severe effect
- N/A = Not Available

Table 5.2 – Valves chemical resistance



Figure 5.6 – Gondolas outlet sockets for Water and Gas

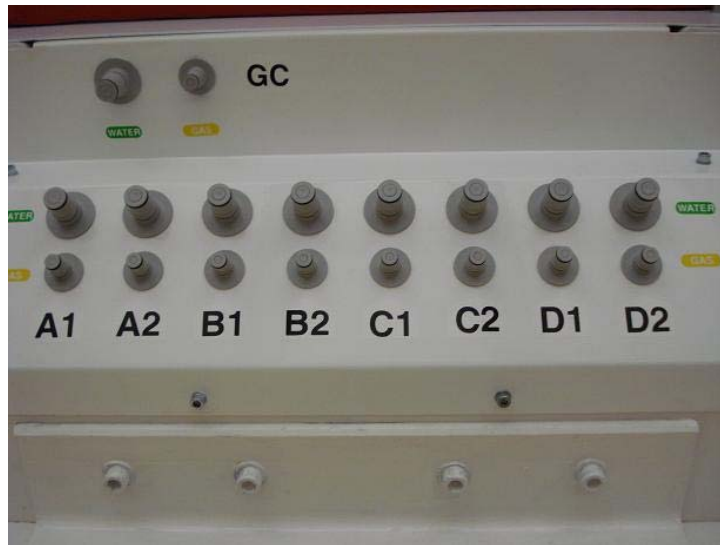

Figure 5.7 – Hub sockets for Water and Gas

5.4 Gas and Water Bottle Cage

The LDC is equipped with 2 bottle cages, 1 in each side of the central hub, for possible installation of gas and water bottles (see Figure 5.8). **If you require gas or water supply for your experiment, the laboratory personnel will prepare the LDC accordingly for you. Please do not forget to provide the respective information beforehand.**

- **Maximum bottles diameter: 250mm**
- **Maximum bottles per cage: 4**



Figure 5.8 – Bottles cage for water and Gas

Document No LDC-ESUM 21082009/JK+AD	Experimenter Specification and Users manual	Revision 21-08-2009	Page 19
---	--	------------------------	------------

5.5 Gondola Electrical Connections

The Gondolas have inside outlets to connect several types of equipments and for power supply.

- AC Power socket, 230V max 6 A (CEE 7/4 Schuko type)
- USB 2.0 (connected to Central PC)
- RS 232 Serial 9 pin connector (max 115 kbps)
- Video Connector (BNC type)
- RJ45 Ethernet Connector (max 100 mbps)



Figure 5.9 – Electrical connections inside gondolas

5.5.1 Gondola USB connection

The LDC has installed an Experiment Control Equipment (PC) in the Hub that can be remotely accessed and where the scientists can install software (and drivers) for remote equipment placed inside the gondolas.

The USB connectors inside the gondolas are wired to the Experimental Control PC using a repeater.

Since some of the USB ports share the same controller the user must take into account the 500mA maximum current drawn from USB 2.0 specifications.

It is possible to connect several equipment to the USB socket using a USB hub

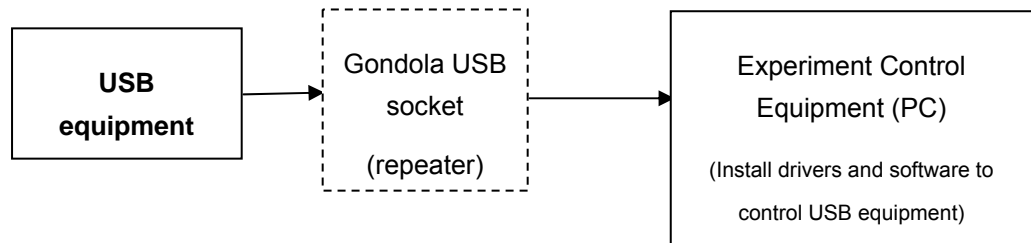

Figure 5.10 – USB connection

5.5.2 Gondola Serial (RS 232) connection

The LDC has installed an Experiment Control Equipment (PC) in the Hub that can be remotely accessed and where the scientists can install software (and drivers) for remote equipment placed inside the gondolas.

The RS 232 connectors inside the gondolas are wired to the Experimental Control PC.

The connection allows a maximum 115kpbs data transfer.

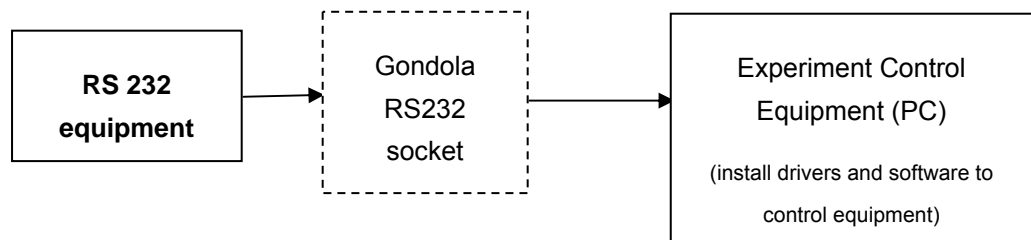

Figure 5.11 – Serial data connection

5.5.3 Video connection

The LDC has installed video extension from the gondolas to the Scientific Station.

The video BNC connections inside the gondolas are wired to Video Panel, see Figure 5.13, passing through a slip-ring. This can transmit Composite video signal.

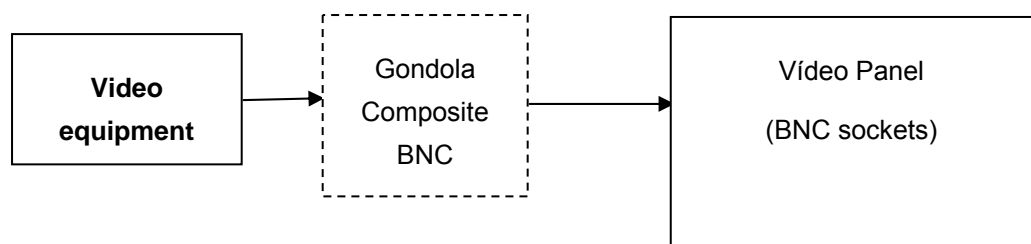

Figure 5.12 – Video signal connection

Document No LDC-ESUM 21082009/JK+AD	Experimenter Specification and Users manual	Revision 21-08-2009	Page 21
---	--	------------------------	------------



Figure 5.13 – Video Panel and Scientific Station

5.5.4 Ethernet connection

The LDC has installed Ethernet from the gondolas to the Scientific Station.

The Ethernet connections inside the gondolas are wired to a switch in the hub, passing through a slip-ring, to a switch in the GCC. There are 2 Ethernet sockets at the Video Panel also. These connections have a maximum bandwidth of 100Mbps to be shared by all the equipment installed in the gondolas mounted in the LDC.

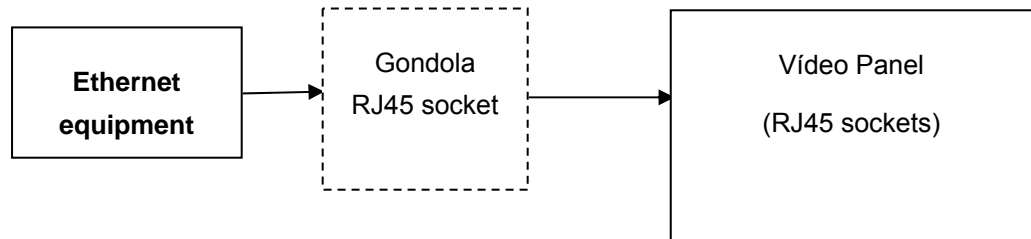

Figure 5.14 – Ethernet connection

6 LDC constrains and safety

6.1 LDC constrains

- High temperature experiments, open flames and similar can not be performed within the LDC gondolas. Exceptions may be discussed but require that the experiment set-up is well contained, autonomous and no hazard to neither the laboratory personnel or the LDC/gondola/ gondola interior

Document No LDC-ESUM 21082009/JK+AD	Experimenter Specification and Users manual	Revision 21-08-2009	Page 22
---	--	------------------------	------------

- LDC gondolas do not provide active cooling
- Power availability in gondola is limited to 1.3 Kw.

6.2 LDC safety

- Every experimenter/experimenting team has to undergo the Laboratory safety briefing and take up responsibility to gain familiarity with the laboratory environment
- Every experimenter/experimenting team commits to follow the instructions of the laboratory personnel
- The experimenter/experimenting team take up responsibility for the safety and safe operation of all brought in equipment
- The experimenter/experimenting team take up responsibility for the safe disposal of brought in equipment and material
- For any brought in equipment and material to be disposed on site of ESTEC the experimenter/experimenting team will consult the Laboratory personnel.

7 Available instrumentation

Please request detailed information.

8 LabView

Please request detailed information