

Galileo System Test Bed Version 1 (GSTB-V1)

The Galileo System Test Bed has been defined as an integral part of the Galileo Design Development and Validation Phase.

The GSTB V1 main objective is to reduce Galileo programme risk on ground segment development by anticipated experimentation on Orbit Determination & Time Synchronisation and Integrity concepts.

Processing facilities pre-developments are conducted to support the refinement of the critical ground segment algorithms and the assessment of related performances based on realistic measurements from the GPS system, in collaboration with the International GPS Service community and UTC time community.

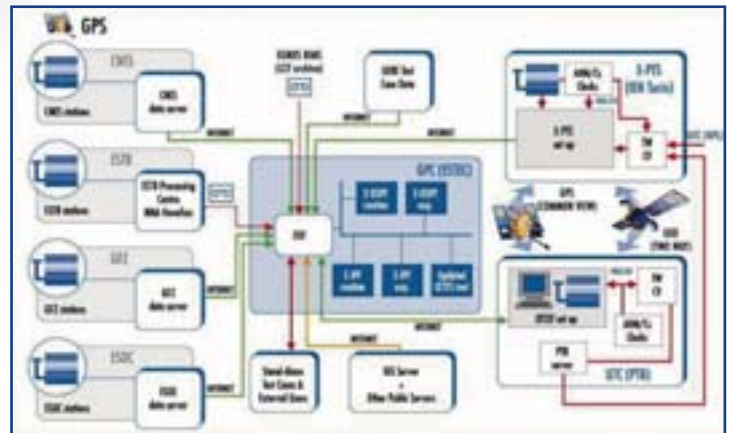

GSTB V1 Core Infrastructure



Experimentation Objectives:

- Orbit Determination and Time Synchronization algorithms performance assessment and comparison of alternative methods.
- Experimental Galileo System Time (E-GST) infrastructure set-up and System Time steering to Universal Time Coordinated/International Atomic Time (UTC/TAI).
- Sensor Stations Range Error budget (Receiver Noise and Multipath) characterisation.
- SISA computation algorithm, Integrity Flag computation and RAIM performance assessment.
- Ionosphere/Troposphere impact assessment and analysis of Galileo concepts to meet high accuracy applications.



GSTB Sensor Station in Vesleskarvet (Antarctica) Courtesy of Norwegian Space Centre

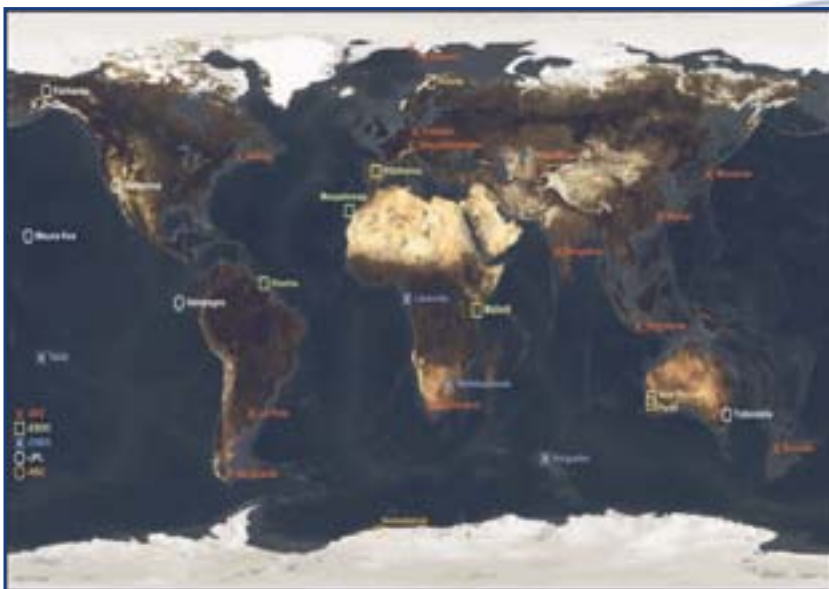

GSTB Global Network of Sensor Stations
(Courtesy of GFZ, CNES, ESA and NASA JPL)

GSTB V1 is an open system experimentation framework: mechanisms have been put in place in the core infrastructure to allow whoever is willing to contribute to receive the core products and experimentation results.

The GSTB V1 experimentation will demonstrate the validity and feasibility of some of the important assumptions and performance objectives of the final Galileo system and will address:

- Actual measurements and comparison of alternative algorithms in a realistic environment;
- Characterisation and Calibration over an extended period of time;
- Build-up, early verification and tuning of simulators and analysis tools;
- Contribution to the consolidation of the Galileo operational concept.



GSTB-V1:

GSTB-V1 has been developed, integrated and validated in 2003 by Galileo Industries.
The GSTB-V1 Processing Centre is installed and operated at ESA ESTEC.
The experimentation phase has been started and results are available through the GSTB-V1 web server: www.gstb-v1.esa.int
In the next step (so called GSTB V2) an experimental satellite will be launched in 2005.

Industry Contact:

Galileo Industries:
Marc GANDARA
Tel. +33 5 34356730
Email: Marc.Gandara@space.alcatel.fr

ESA Contact:

Marco Falcone
Tel. + 31 71 5655832
Email: Marco.Falcone@esa.int
www.gstb-v1.esa.int

GalileoTech News are being released on a case by case basis and are intended for general information only. For more comprehensive and up-to-date information please contact the Galileo Project Office at ESA-ESTEC

Tel +31 71 565 3193
galileo.project@esa.int

www.esa.int/navigation

