

GMES Space Component Pre-operations 2008-2010

GSE collocation #5

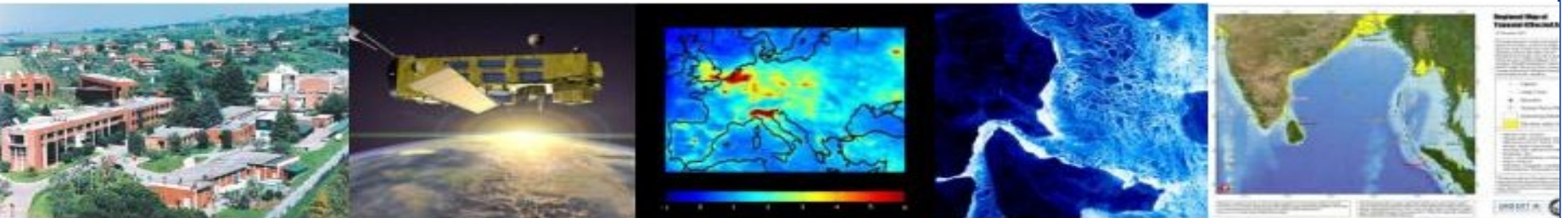

7th March 2007
ESA ESRIIN Frascati

- 1) Overview GMES Ground Segment & Data Access (10 min)**
- 2) GMES Data Access Portfolio for 2008-2010 (20 min)**
- 3) GMES operations concept for 2008-2010 (15 min)**
- 4) Heterogeneous Missions Accessibility (20 min)**

Overview

**GMES Space
Component
(GSC)**



**GMES
Services**

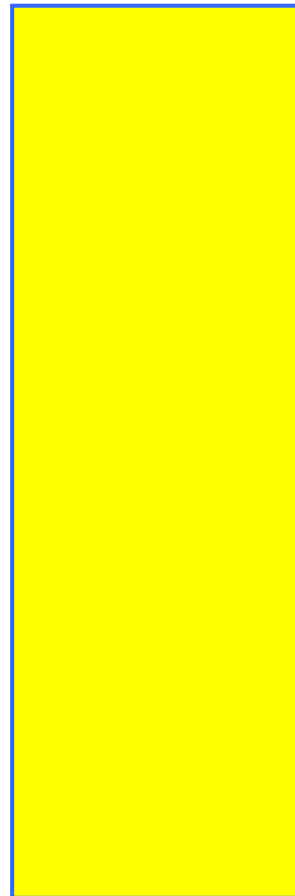

**GMES
Information
Users**

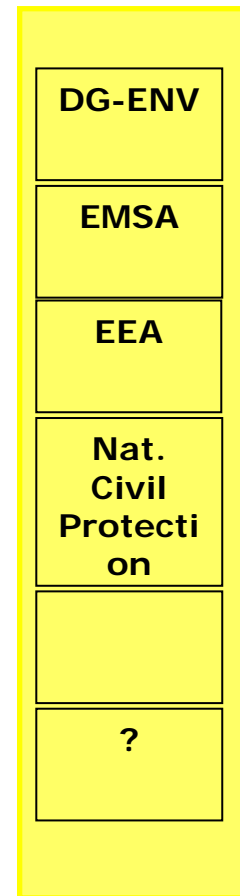

- *is the sum of the EO resources & infrastructure in space and on ground, delivering the data necessary for the GMES Service*
- *until 2011 it shall consist of 'contributing missions'*
 - ❑ *From ESA and some international partners*
 - ❑ *From national entities*
 - ❑ *From commercial operators*
 - ❑ *From Eumetsat*
- *after 2011 it shall consist of dedicated GMES satellites plus a number of contributing missions*

Which all together shall in their sum provide the sustainability to meet (at best) ALL requirements from GMES services

- **Serve by 2008 pre-operations of fast track and other GMES Services**
- **Provide the Sentinels' ground segment according to their development, test and integration schedule (L=2011)**
- **Provide coherent access (*) to all required EO data**
 - Current and historic ESA data
 - Current and historic ESA TPM data
 - Data from contributing missions (National, Eumetsat, Commercial)
 - Some additional non-European data (as required)

(*) See definition of '[data access](#)'

✓ **User Interfaces:**

- Web-portals, News, Information
- Catalogues and Data Description
- Data selection and Ordering Mechanisms,
- Payment mechanism,
- Reporting mechanism;
- Data and Quality Description

✓ **Data:**

- Formats,
- Product definition across missions
- Processing levels (lvl1, ..., Ortho-rectified...lvl 3)
- Quality assurance across different data sets

✓ **Delivery:**

- physical, internet, telecom sat. links,
- direct down links
- global or selected data sets
- delays (30min, 3h, 8 h, 2 weeks);

✓ **Policy:**

- IPR across missions,
- Cost for users,
- Data sharing and Re-Use rights

What provides for the GMES Services

The Need
User requirements

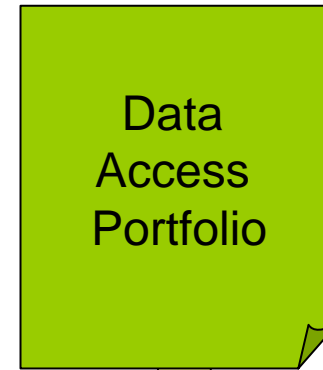

The Possible
data contribution

How ?

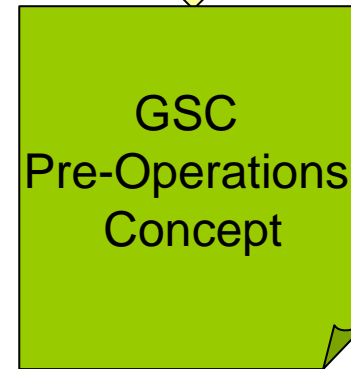

By when ?



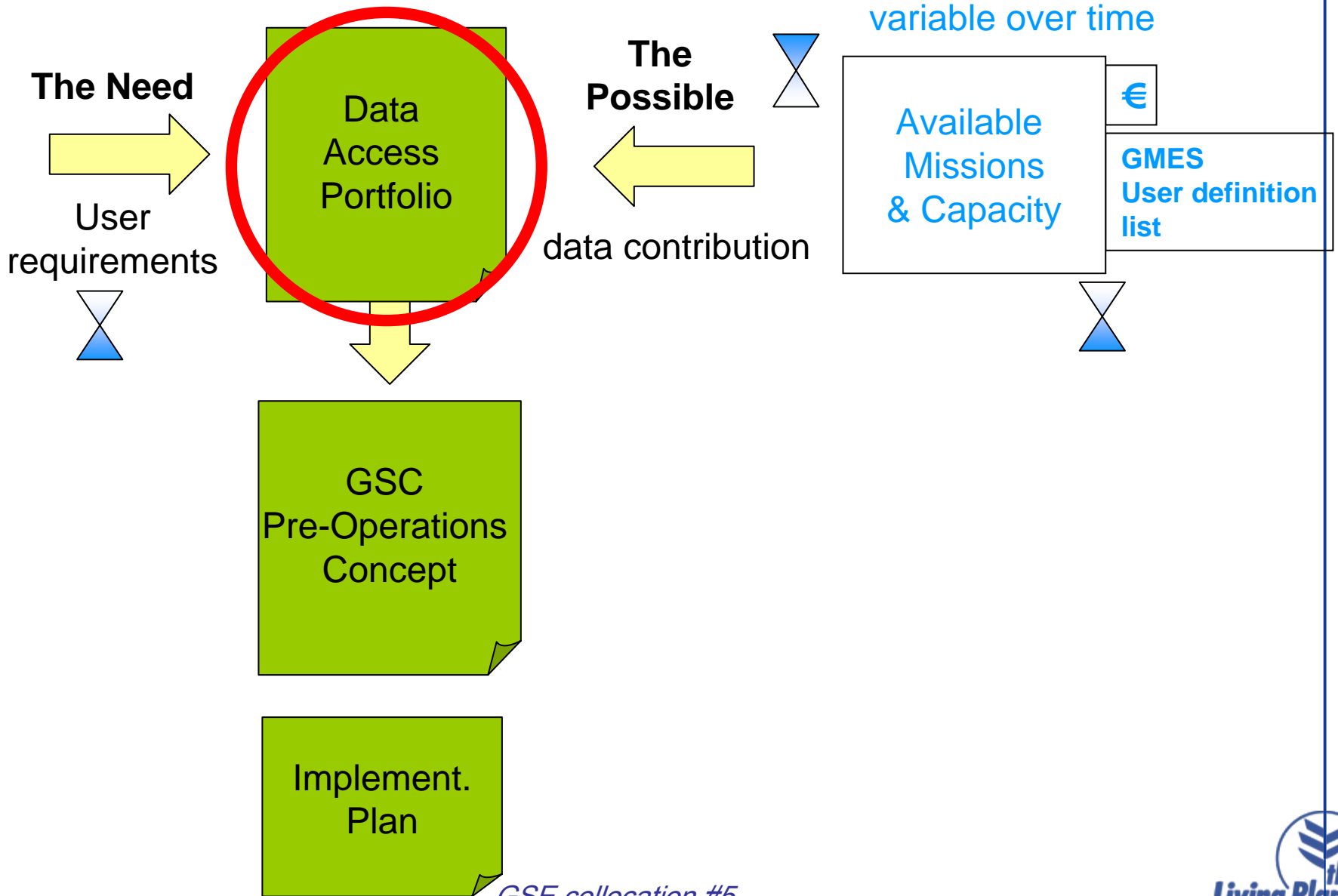

GSC USERS AND GMES SERVICES

GMES Services to be served by the GSC in 2008 include at least:

- **The Marine Core Service (MCS) ***
- The Marine Downstream services (MDS)
- **The Land Core Services (LCS) ***
- The Land Down Stream services (LDS)
- **The Emergency Response Core Services (ERCS) ***
- The Emergency response down stream services (ERDS)
- **The Security Pilot Service ***
- EC FP6 Integrated Projects
- **The Atmosphere Pilot Service ***
- The ESA GSE Services (GSE) and, and future DUE Services both in development and in operations at that time.
- Other EC defined (FP7 service oriented/Space Theme?) * & EU Services (ECS) JRC, EMSA, EUSC ? → major cost driver for IPR

* data access for those projects is funded through FP7 data access grant

“Sentinel” =

- ❖ *a spacecraft or instrument dedicated to GMES and built and launched for GMES (e.g. sentinel 1A or 3A etc)*

and also

- ❖ *a defined acquisition capability:*
 - *Sentinel 1 group = \sum SAR acquisitions
(ERS+ENV+ RS 1-3+ TS-X,+Cosmo+ Alos etc)*
 - *Sentinel 2 group = \sum high resolution optical
(Spot+Landsat+Alos + RE +Proba + DMC etc)*

Based upon the data needs for GMES there are 5 groups called sentinels or sentinel groups:

Sentinel 1 – High-resolution SAR imaging

All weather, day/night applications, interferometry

Sentinel 2 – High-resolution multispectral imaging

Continuity of Landsat, SPOT data

Sentinel 3 – Medium-resolution Ocean monitoring

*Wide-swath ocean color and surface temperature sensors,
altimeter*

Sentinel 4 – Geostationary atmospheric

Atmospheric composition monitoring, trans-boundary pollution

Sentinel 5 – Low Earth Orbit atmospheric

Atmospheric composition monitoring

Why:

- **Revisit for coverage**
- **Shortest possible re-planning time**
- **Sustainability (in case of one mission getting lost)**
- **Compensating for different priorities of different missions**
- **Cost efficiency**

Requested by Fast Track Implementation Groups:

- ***“to guarantee a continuous and sustainable feeding of the LMCS by EO data and to reduce dependencies from a singular mission approach, a coordinated multi-mission tasking and ordering capacity...is seen as necessary in the short-term” [GAC/2007/5]***
- ***“flexible multi-sensor ordering; long-term perspective” [GAC/2007/5]***

1. **Fully European (incl. Canada) owned and operated**
 - a. flying today: Envisat, ERS, Radarsat-1, ALOS (for Europe), MetOp, MSG, Spot4, Spot5, DMC-UK (representing the constellation)
 - b. flying 2008/2009-2010 for DAP1: TerraSAR-X, Radarsat-2, *Cosmo SkyMed, RapidEye, DMC/Deimos*
2. **non-European owned but European GS operations**
 - a. flying today: IRS-P6, Ikonos-2, JASON -1, Kompsat-2, Formosat-2, SeaWifs, MODIS
 - b. flying 2008/2009/2010 for DAP1: Cartosat-2, GeoEye-1, JASON-2, THEOS
3. **non-European owned but reseller industry in Europe**
 - a. flying today: Quickbird, EROS-A/-B
 - b. flying 2008/2009/2010 for DAP1: Worldview , Oceansat-2
4. **any other non-European**

Accepted GMES Services will as output of the GSC

- all have equal data access conditions
 - same Terms and conditions for data use
 - all products for all GMES services
 - Harmonized technical interfaces for data access
 - No a-priori priorities among services (with special access for ERCS, e.g. rush planning)

- receive the data at no charges (up to a certain agreed quota)

Data Access Agreements

Use - Compensation

TPM 1	Cat-1 Cat-2	Data Exchange
TPM 2	Cat-2 GMES	Bulk Purchase
TPM 3	Cat-1	none
TPM 4	Cat-1 GMES	GS Dev Operat.
TPM .n		

Declaration

EE	Cat-1, GMES
Sent. 1,2	GMES

Coherent Data Access

User Agreements

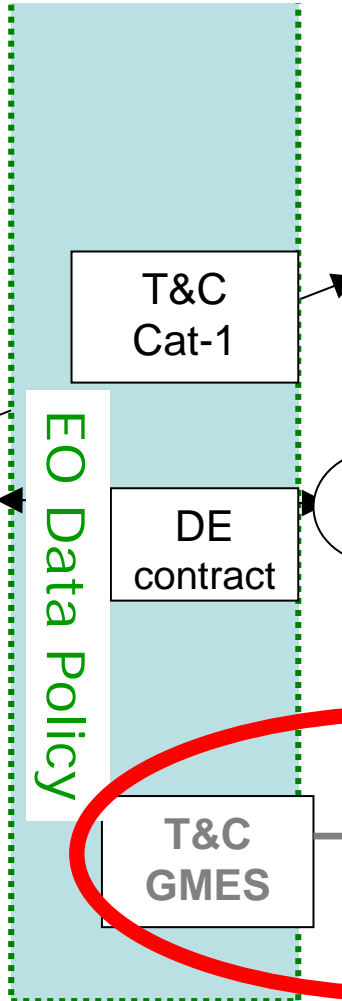

Information End Users

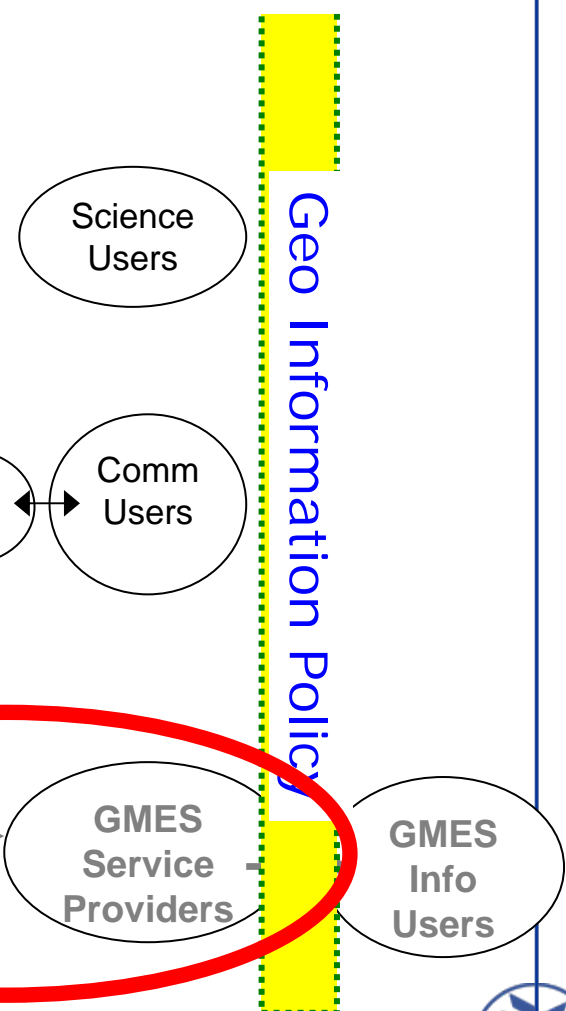

- *Will be formal part of the DAP*
- *To be signed by every GMES service responsible*

- *onward distribution of EO (pre-processed) data requires signature of Terms and Conditions by each recipient project;*
 - *i.e. Core and Downstream services and any end-user receiving part of pre-processed data*

- *feedback, publication of service results with quoting EC, ESA and other EO data sources*

Implications

- *T&C are formal part of the contractual relation of ESA with mission operators to be established in 2007*
- *T&C and “data use(rs)” determine the cost for access to contributing missions*
- *T&C may evolve in time*

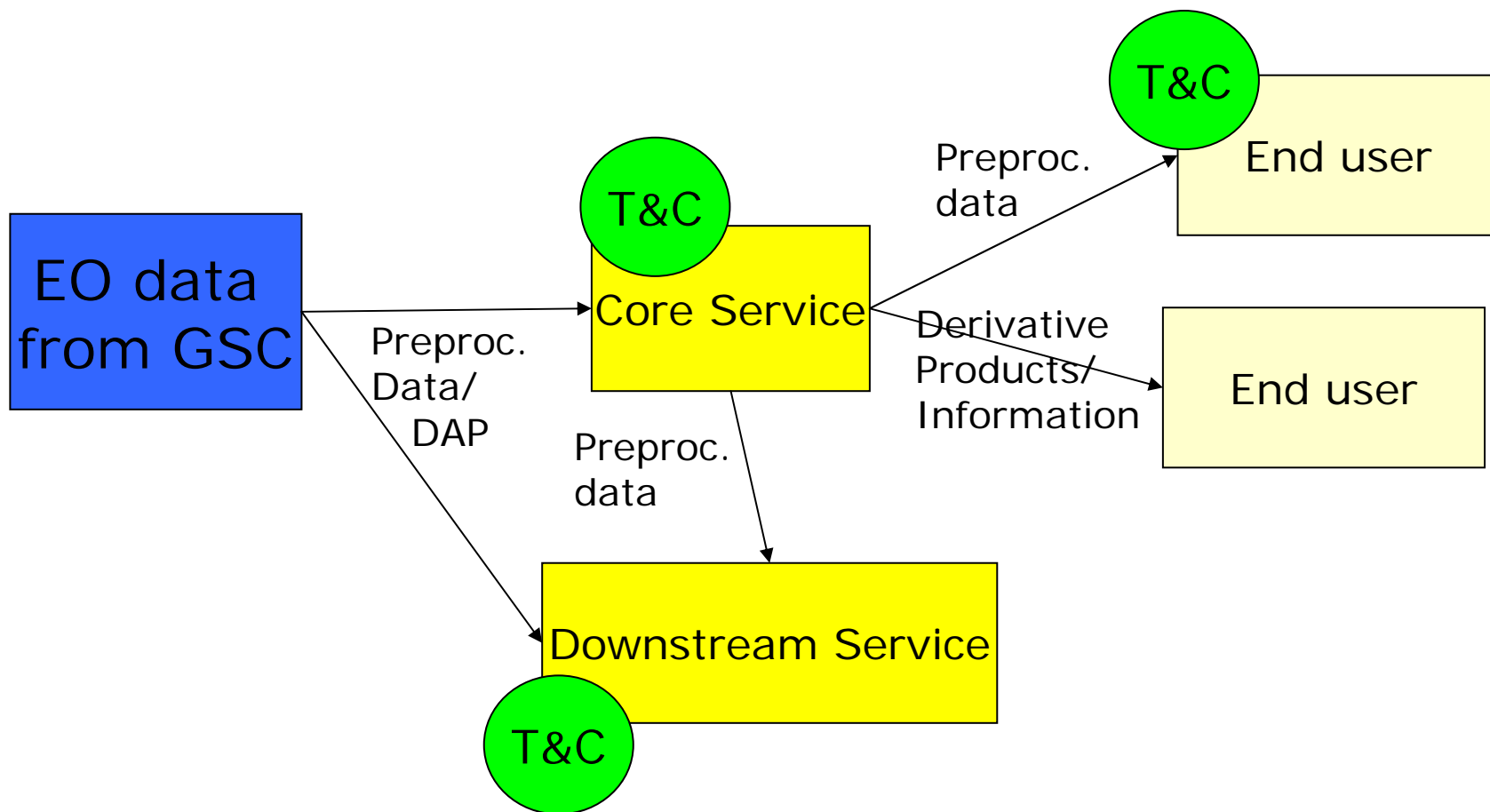



GSE collocation #5

Pending signature of agreement and operations contract:

Sentinel 1 – Group: ERS, ENVISAT, Radarsat1, Radarsat2, TS-X, Cosmo, Alos

Sentinel 2 – SPOT 4, Spot 5, Kompsat, Formosat, Rapid Eye, DMC-UK, Proba, DMC-Deimos, Alos, IRS-P6, Landsat

[Sentinel-2b/VHR: Pleiades, Ikonos-2, Quickbird, Geoeye-1, Worldview, Orbview-3, Cartosat, Eros]

Sentinel 3 – Meris, AATSR, ATSR-2, ERS&ENV RA, Metop, Jason, Modis, Vegetation, SeaWifs

Sentinel 4 & 5: not part of current plan



Example of Requirements Analysis LMCS

Service	Application	Coverage	Satellite Tasking	Delivery Time	Resolution	Mapping interval	Sensor	Optical bands	SAR Bands	List of optical sensors	List of radar sensors
LCS	Land cover & change monitoring	EEA-38	Predefined	Normal	HR	Every 3 years	Optical, SAR	VIS, NIR	C, L	SPOT4, ALOS, SPOT-5, Rapid Eye, IRS-P6, DMC (UK, Deimos), THEOS	Envisat, Radarsat 2,
LCS	European Urban Atlas	Big European cities	Predefined	Normal	VHR	Yearly	Optical, SAR	VIS, NIR, PAN	X	SPOT-5, KOMPSAT-2, Formosat-2, Orbview-3, Quickbird, IKONOS-2, Geoeye-1, Worldview	TerraSAR-X, Cosmo SkyMed

<p>Questions based on IG docs = variations in amount/cost</p> <p>EU landcover</p>	<p>years</p>	<p>High Cost estimate for 3 years</p>
<p>LFTS: 2 coverages in 1 mapping event=3y; IG: 3-5years or annual incl. orthorectif. and mosaicing EU= EU38? ; SWIR? absolute geometric accuracy orthorectification for HR in GSCor outside (IACS)? s... VHR? atmospheric corection? automated... License/Re-use of IACS "any non-commercial f... complementary use"? Euro-DEM? Is a DE... Timeplan: Annual EU cover... (10-30m) Integration of... 2009? Start global? Frequency "from w... HR or HR data? [GAC/2007/4]</p>	<p>€6,000,000</p>	<p>€22,950,000</p>
<p>EU Urban Atl... ...port IG/Implementation Plan: ... for VHR, absolute geometric accuracy 5m 2007: 300 cities over 3 years 2008: 500 cities SAR: 10% of all cases in X-band [GAC/2007/4] ,</p>	<p>€500,000</p>	<p>€3,500,000</p>

ESA decision on best knowledge, available budget and in coordination with EC and Services

EU landcover

Assumptions on minimum data provision in DAP1	DAP provision 2008-2010 (3 years), from the below missions
<p>1-3 coverages for 3 years for EEA-38 (Fixed dataset in predefined windows) L1A + (optional) orthorectified</p> <p>Global component can be used from existing Envisat MERIS and VEGETATION</p> <p>GCP + DEM</p>	<p>Spot4/5, ALOS, DMC-UK, DMC Deimos, Rapideye</p> <p>IRS-P6, Landsat</p> <p>Backup: Envisat, RS-1/2</p> <p>Aux: EU-38 GCP, SRTM C-band</p>
<p>500 European cities 1 time in 3 years optional orthorectified</p>	<p>Spot5</p> <p>Ikonos-2/Geoeye-1, Kompsat-2, Formosat-2</p> <p>Quickbird/Worldview backup: TS-X</p>

EU Urban Atlas



Area [mio. Km ²]	EO-data type*	Frequency	Use
Europe [5,8]	HR	Every 3 years**, Bi-temporal	<i>Key information source</i>
		All years, seasonally	seasonal vegetation development, selected hot spots /pilot areas
	MR	All years, seasonally	To track vegetation and cycle & to cope with climate variability
	VHR	Every 5 years	500 cities (Urban Atlas)
All years		validation, verification, AFS yearly tracking, selected pilot areas/hot spots	
Africa [30,3]	MR	All years	seasonal vegetation development <i>Key information source</i>
	HR	All years	validation, verification & selected hot-spots
Global [510,1]	LR	All years, Daily to monthly	<i>Key information source</i>
10 – 20% additional EO data (service evolution / new sensor type needs on project level)			

* VHR: 0,5 – 5 m; HR: 5 – 30 m; MR: 60 – 300 m; LR: >300 m

** planned all years, depending on capacity of EO sensors

GSE collocation #5

Optimal data provision

Service	Application	Coverage	Satellite Tasking	Delivery Time	Resolution	Mapping interval	Sensor	bands
LCS	XYZ	EEA-38	Predefined	Normal	HR	Every 3 years	Optical	VIS, NIR
		EEA-38	Predefined	Normal	VHR	Every 3 years	SAR	C, L
LCS	sdashdja	50 cities	Predefined	Normal	VHR	within 1 year	SAR	X, C
Emergency	klai	10-20 cities	On-demand	NRT	VHR	assumed 1/month	optical	VIS, NIR

Minimum data provision required to be able to run the service

Service	Application	Coverage	Satellite Tasking	Delivery Time	Resolution	Mapping interval	Sensor	Optical bands
LCS	XYZ	EU27	Predefined	Normal	HR	Every 3 years	Optical	VIS
		EU27	Predefined	Normal	VHR	Every 3 years	SAR	C, L
LCS	sdashdja	30	Predefined	Normal	VHR	within 2 years	SAR	C
Emergency	klai	10	On-demand	NRT	VHR	assumed once/2 months	optical	VIS

THIS REQUIRES YOUR INPUT!!

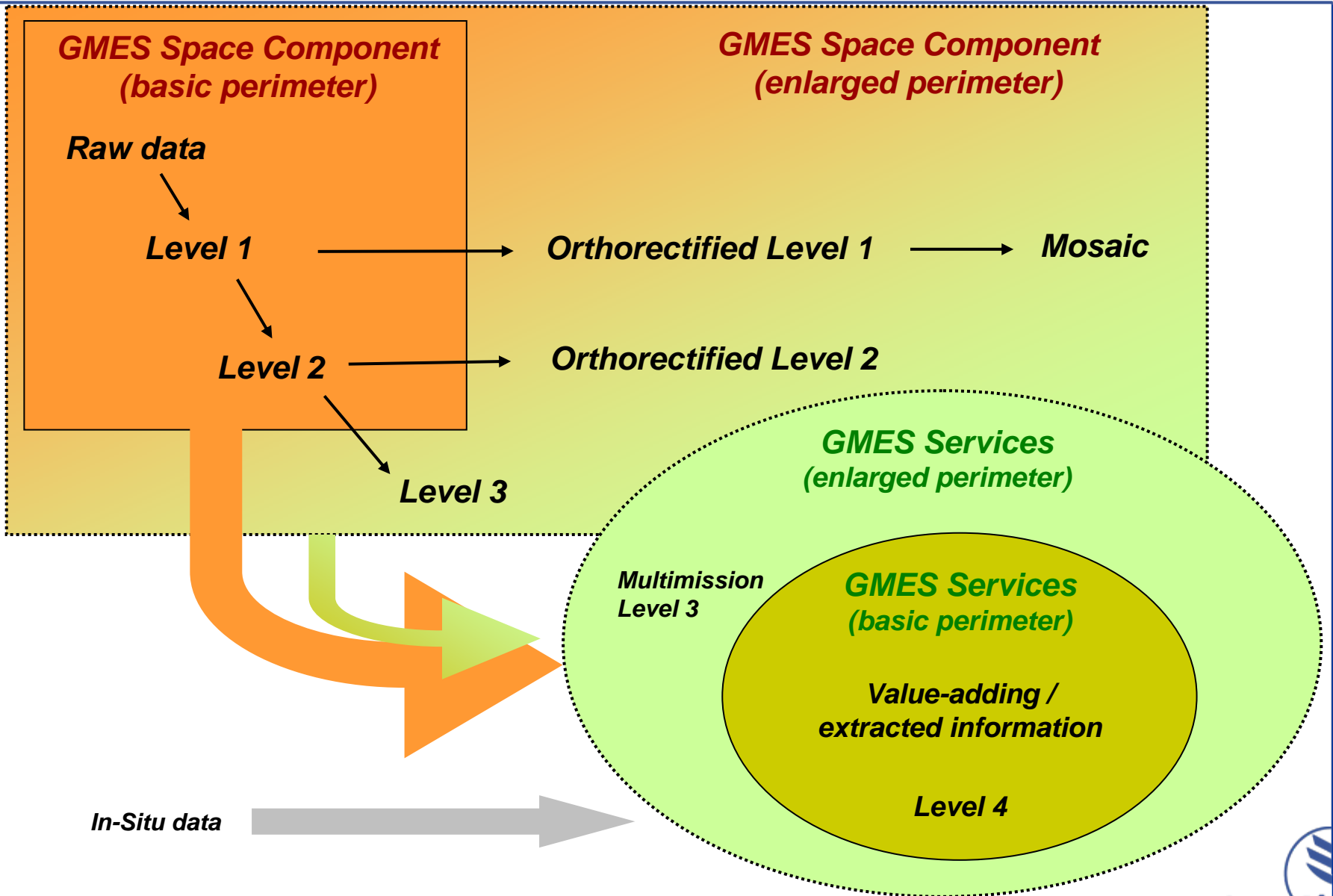

- Existing Standard Products from all contributing Missions
- Level 1 and 2 products
 - Higher level processing will be provided if required by more than 1 service, subject to budget availability, e.g. orthorectification or special level 3 products (mosaic)
- Optional Infrastructure support for level 3 & 4 products and their dissemination (Service Support Environment, Hiseen-Network, GEONET, Grid-on-demand, Classification tools, Server maintenance)

Systematic dataset

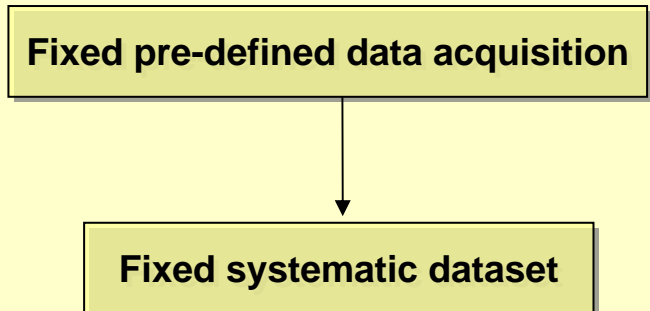

Examples:

- yearly cloud free optical HR coverage of Europe
- pre-defined SAR acquisition for sea-ice monitoring
- acquisitions from systematic instruments (e.g. altimeter)

Examples:

- complete optical HR products of Europe
- systematic SAR Medium Resolution products
- NRT products from systematic instruments (e.g. altimeter)

70 - 80 % of data portfolio volume

On-demand dataset

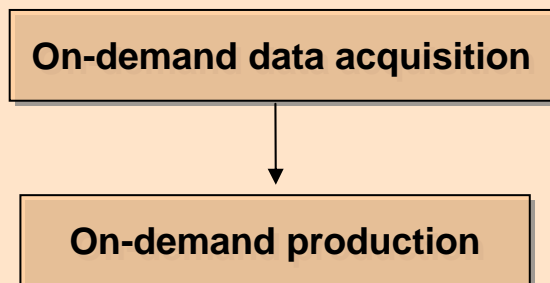

Rush satellite tasking
(e.g. for emergency planning)

NRT delivery of products related to rush satellite tasking

10 - 20 % of data portfolio volume

➤ Satellite Tasking:

- Rush → this will depend on satellite lead times
- Pre-defined

➤ Delivery/ provision in DAP1:

- NRT1h → online data provision; few data/missions
- NRT3h → online data provision; subset of data/missions
- Fast=24h → online data provision
- Normal= x days → online/media; default for all data, especially collections (e.g. full European coverages)

March 2007

EO-DAP Version 0

→ based on data needs assumptions and potential

During this time requirements can still be integrated into DAP1

- negotiation of agreements with GMES Contributing Missions,
- in parallel, refinement of EO-DAP Version 0 with new releases according to outcome of agreements negotiation and improved

At this time requirements may not be considered into DAP1!!!

January 2008

EO-DAP Version 1 Release 0

→ to be used for 2008-2009

Implementation phase
of EO-DAP Version 1

→ GMES Services gradually served

July 2008

Validity phase
of EO-DAP Version 1

→ New releases of Version 1 with minor upgrades over time, necessary to cope with unpredicted important requirements or with satellite unavailabilities

December 2009

EO-DAP Version 2 Release 0

→ to be used for 2010-2011

Status on ESA missions

Status on Third Party Missions

Envisat mission just reached its 5-years nominal lifetime

- instruments working nominally, in particular ASAR, MERIS
- satellite OK with mid-term operations capabilities [50 % of fuel available, i.e. about 3 years assuming same orbit control strategy: +/- 1 km]

Envisat operations funding until 2010

16 years of ERS-1/2 data in the archive

On-going effort of product/algos standardization between ERS and Envisat missions

ERS-2 mission about to reach its 12th years in orbit

Some problems with the platform with workaround solutions implemented, e.g. on-board recorder failure in 2003 compensated with set up of a stations network for Low Bit Rate data acquisition.

ERS-2 operations funding until 2008

	Missions	Sensor	Data Coverage	Time coverage	Today available on
Historic	IRS-P3	MOS	Maspalomas station circle	1998-2004	on-demand, media
	JERS-1	OPS	European station coverage	1992-1998	on-demand, media
		SAR			
NIMBUS	CZCS	European station coverage	1978-1986	on-demand, media	
Operational	Proba	CHRIS	Global	2001-today	systematic online, ftp
		HRC	Global		
	Landsat	MSS, TM, ETM	European coverage	~1990, ~2000	systematic online, ftp
	KOMPSAT-1	EOC	European cities	1999-2004	systematic online, ftp
	SCISAT-1	FTS	Global	2003-today	systematic online, ftp
		MAESTRO	Global		
	Terra/Acqua	MODIS	Europe/North Africa	2001-today	on-demand, media
	NOAA	AVHRR	Europe/North Africa	1984-today	on-demand, media
	QSCAT	SeaWinds	Global	2000-today	systematic online, ftp
Orbview	SeaWifs	Europe/North Africa	1998-2004	on-demand, media	

			Data	Time	Today
	Missions	Sensor	Coverage	coverage	available on
	<p>SPOT: Opening of online L1A SPot2-SPot4 archive within next 1-2 weeks with > 11.000 products!!</p> <ul style="list-style-type: none"> • 10m pan • 20m multispectral <p>+ capacity for new acquisition planning</p> <p>– GSE are eligible to order under Cat-1</p>				
	<p>ALOS: Finalisation of internal testing - Opening for Cat-1 external users within few weeks</p> <ul style="list-style-type: none"> • 10m multispectral • 2.5m pan (stereo) • 12.5m (L-band SAR) <p>– GSE are eligible to order under Cat-1</p>				
	KOMPSAT-2	MSC	Europe, Africa, some	TBD	on-demand, FTP (default), media (on request)

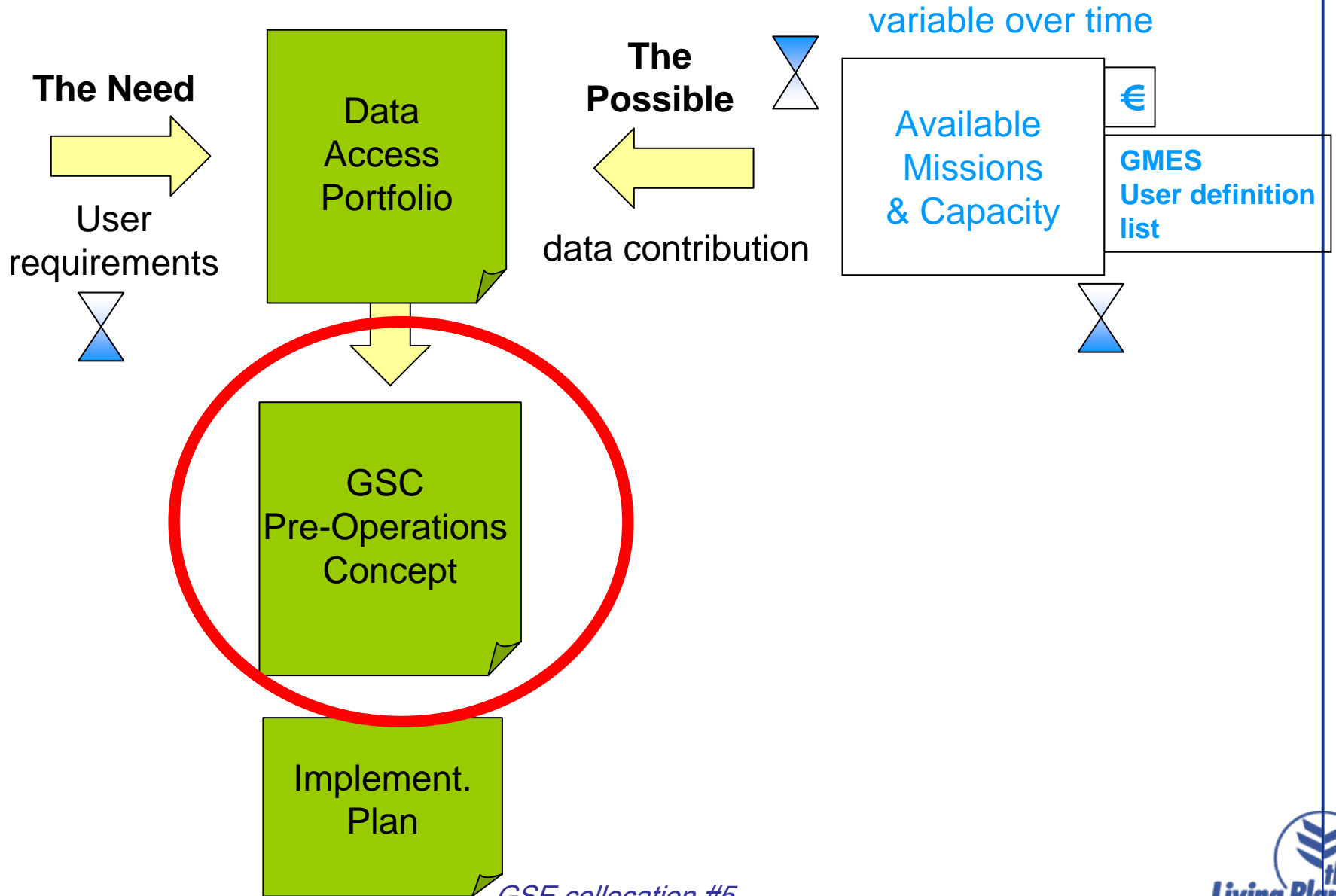

- 1) Scenario**
- 2) Distributed GMES Ground Segment**
- 3) Data Access Services**
 - ✓ GSC portal
 - ✓ Distributed Order Desk
 - ✓ Data delivery Services
- 4) Coordination support Services**
- 5) Staged Implementation approach**

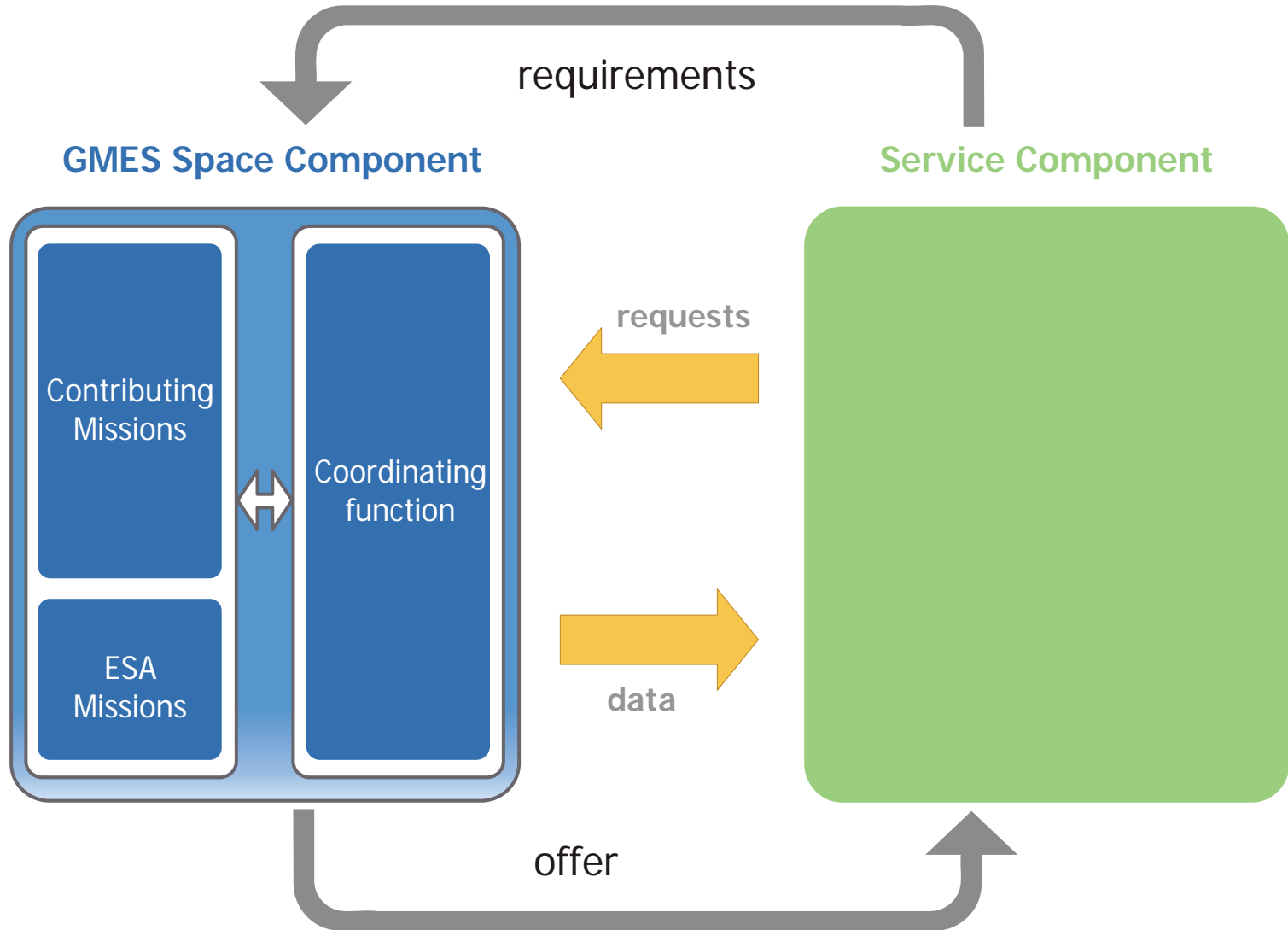

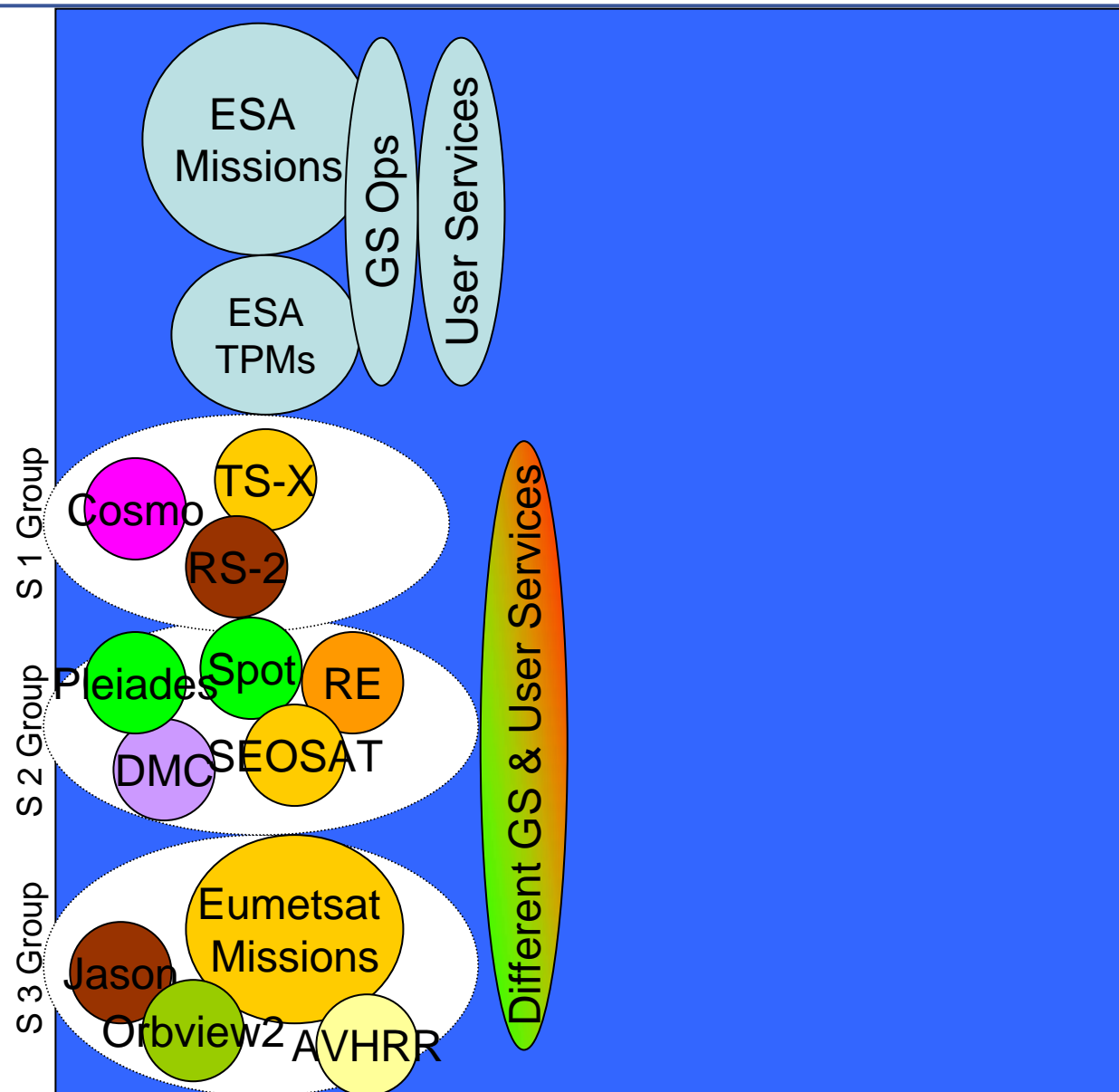

- Marine Core Service
- Land CS
- Emergency Response CS
- Others tbc
- GMES Services (EC Managed)

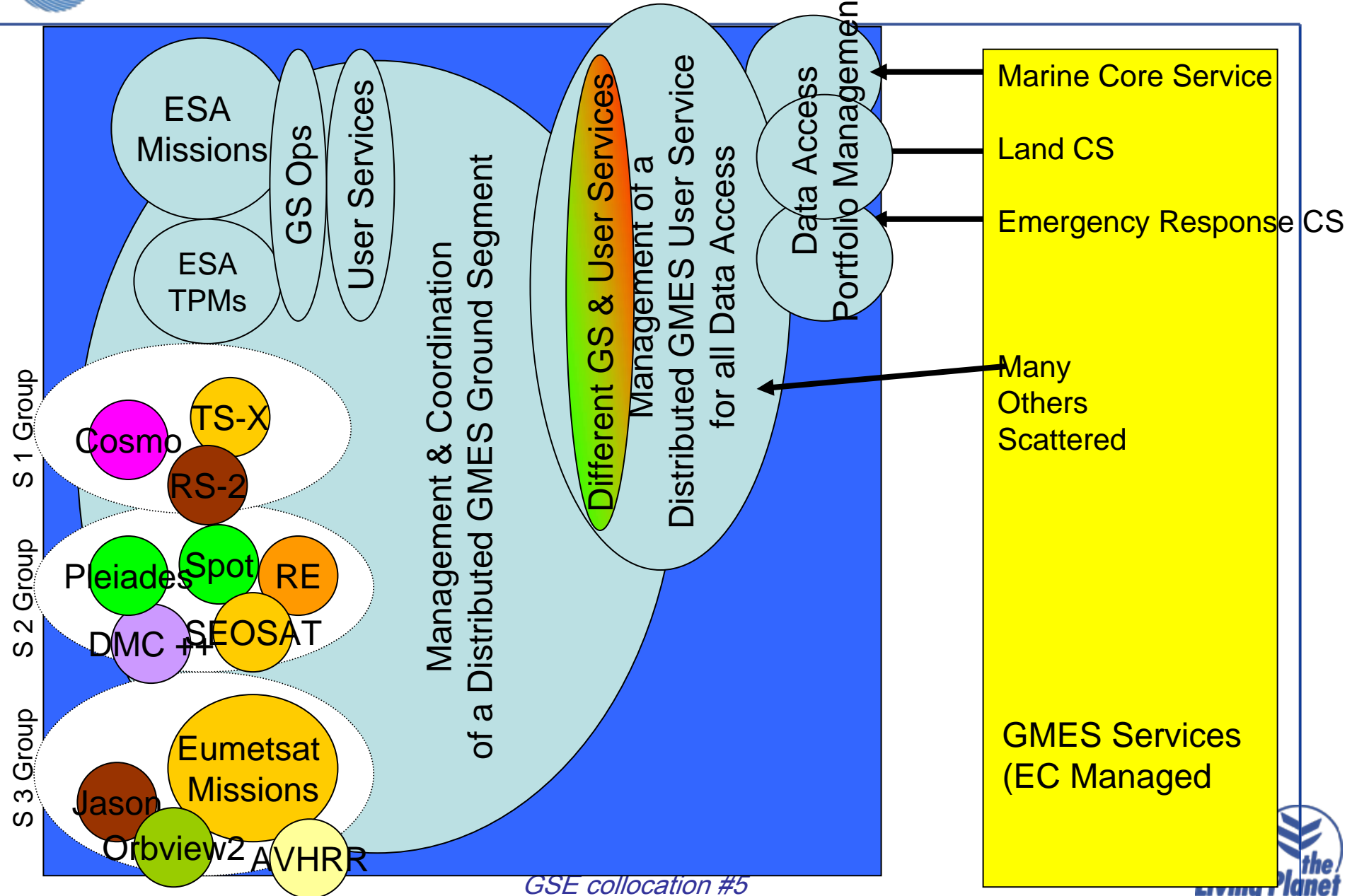

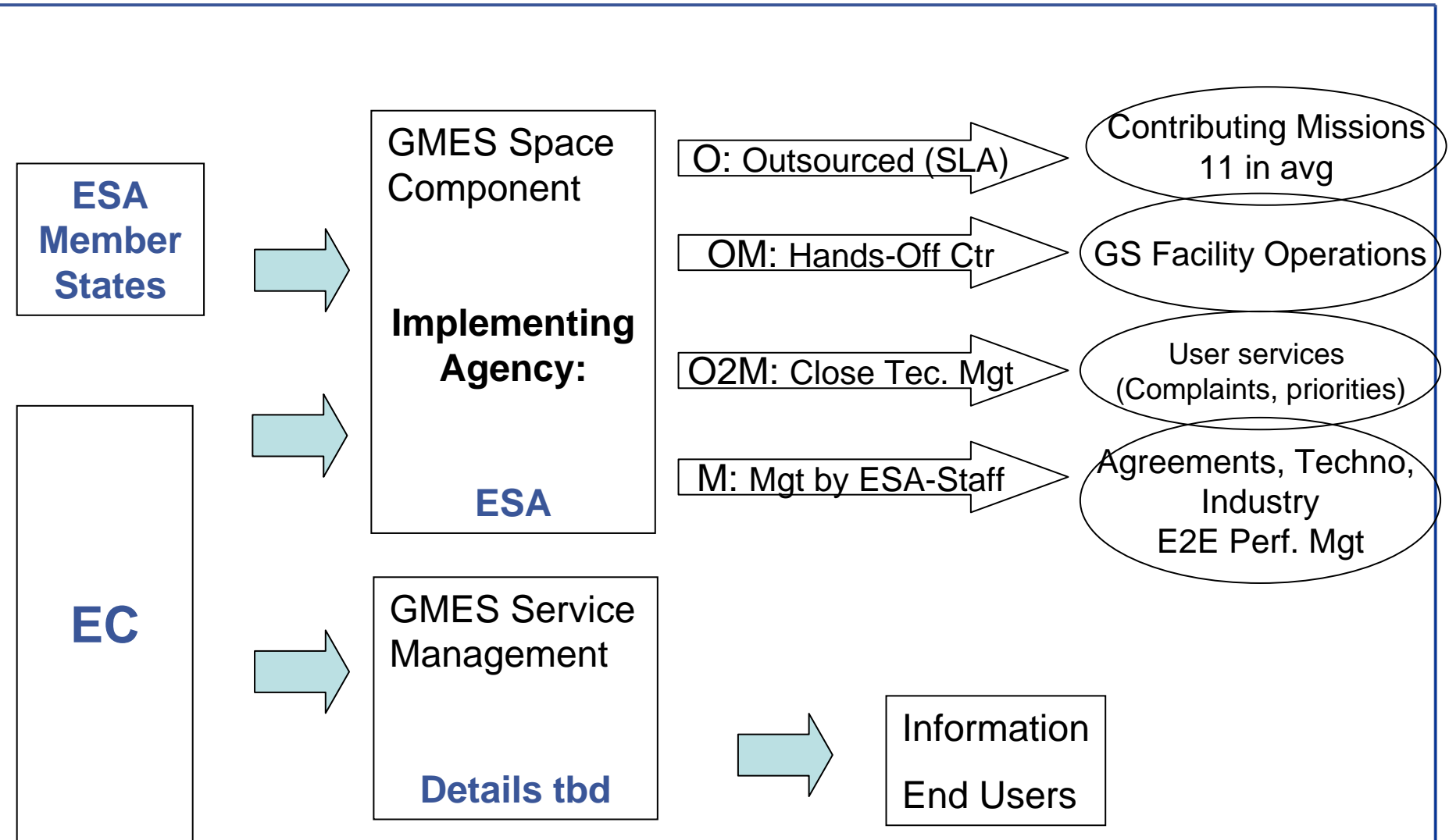

ESA for the GSC shall :

- I. set-up the technical interfaces to the above contributing missions (I/F development ctrs)

- II. Establish the legal data access agreements either through 'Agreements', Letters or contracts.

- III. Establish operations contracts (SLA) with its own industry and jointly with the operators of contributing missions to assure coherent end-to-end GSC scenario.

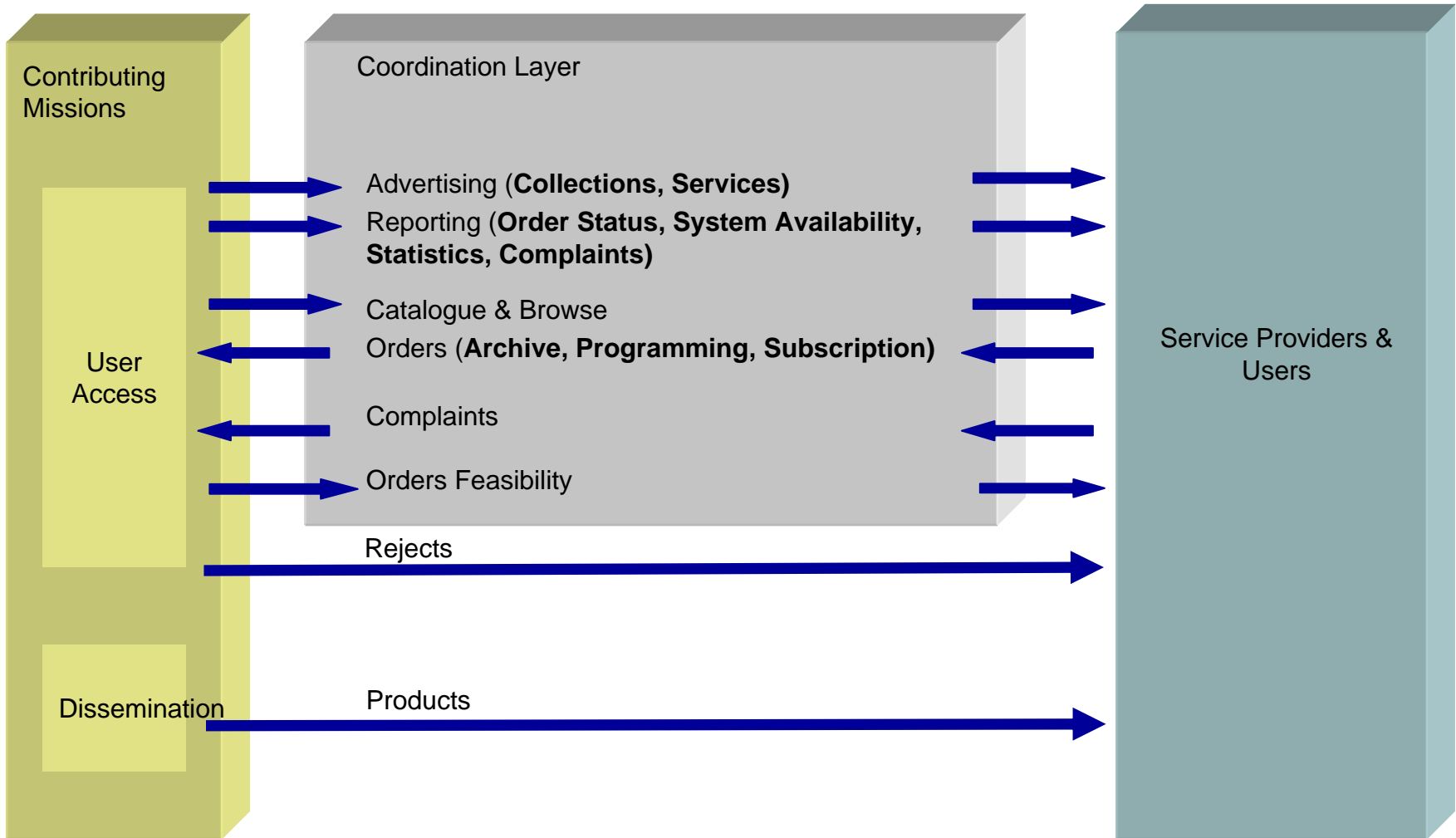

- Neutral
- Has to give full visibility to all GSC contributing missions
- Based (technically) upon the GEOportal/EOPortal, but
 - GMES-specific
 - Addressing to service providers (rather than general public or information end-users)
 - Linked as sub-element to GMES-Services Portal (between service providers and information users)
 - Using HMA approach and technology
- Support
 - the large core service managers
 - the downstream services
 - the GSC service managers interface
- Prototype to be presented in April 07, pre-operational version in Nov 07

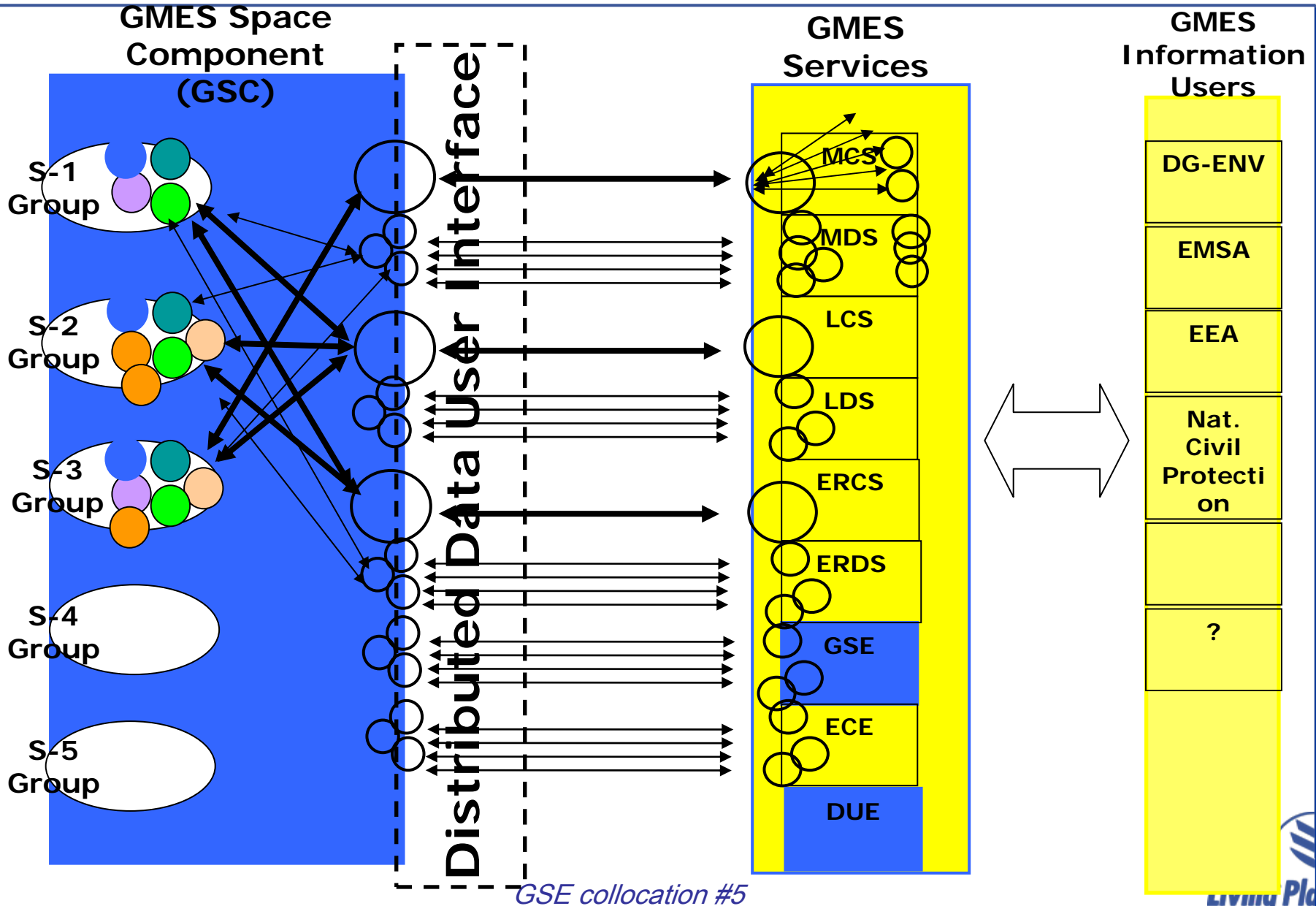

Interface to *few* Core Service Managers

Service-Side: 'bulk requirements' single interface point: 'xx Core Services Manager'

GSC-Side: Dedicated 'xx Services I/F & Account Manager'

Interface to (*many*) Downstream, national, GSE ...Services

Service-Side: many individuals

GSC-Side: On-line ordering, generic order desk

Interface to *Emergency Response*

Service-Side: some predefined individuals

GSC-Side: Same team of Operators as for Charter-Calls (with specific GMES procedure)

Every Mission Operator (*)

- ✓ already operates and Order Desk and User Services
- ✓ wants and needs direct visibility to and from the service

The GSC (virtual end-to-end) distributed User Services

- ✓ will ensure the end-to-end satisfaction of the EO data needs
- ✓ will provide a coherent, easy, simple, fast interface to a set of distributed EO data sources
- ✓ will trace all EO data provision from any mission to any service
- ✓ Is the final Responsible towards the Services for the Interface Performance and the GSC data portfolio

(*) e.g. Spotimage, Infoterra, Eumetsat, Rapid Eye etc

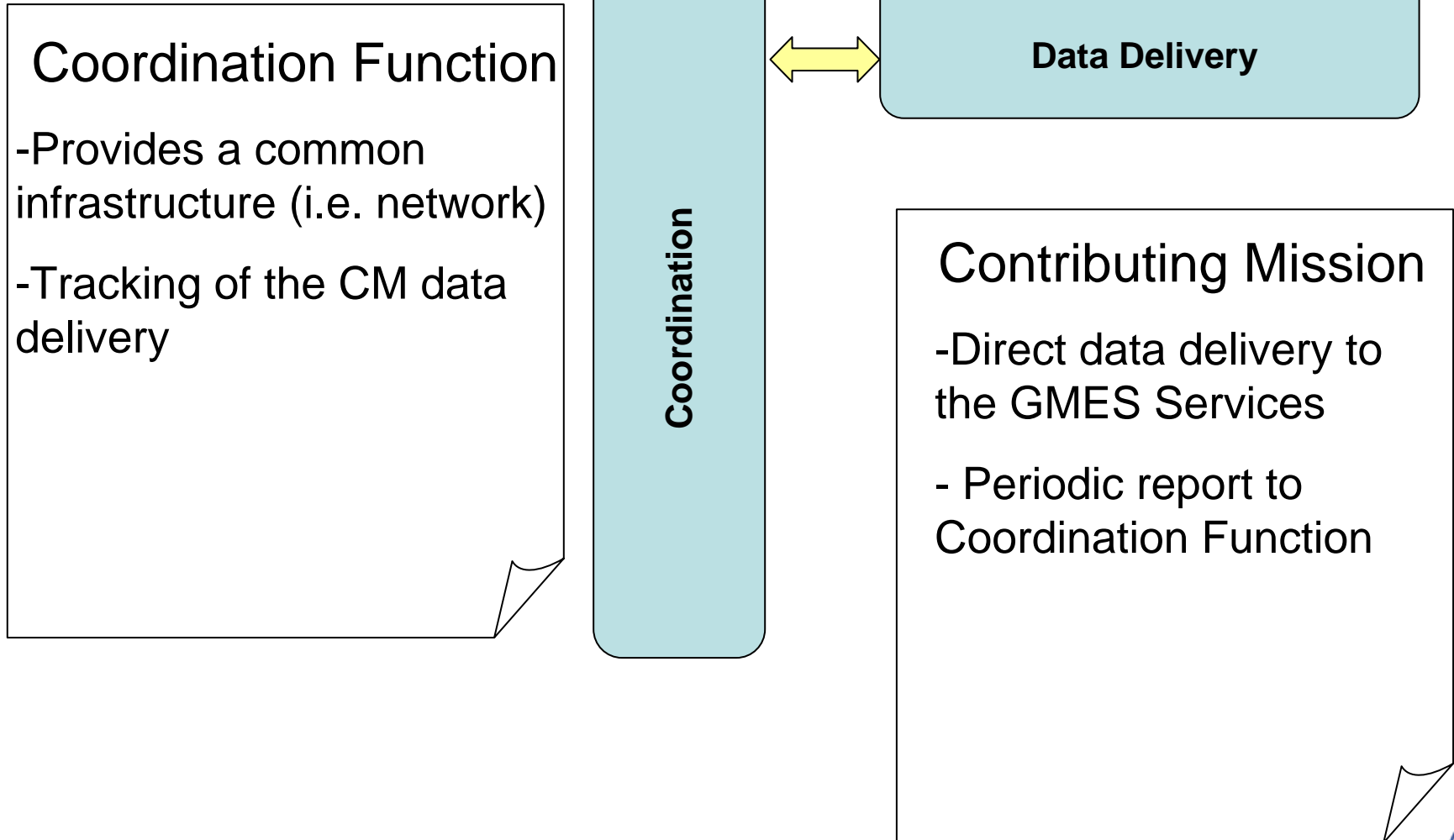



Gatineau & Prince
Alabert In
Canada

The Centres today operate

- Scientific missions
- Public national missions
- Commercial missions
- Eumetsat missions



Esa RT stations
Non Esa RT stations

Maspalomas

Antarctica:
O'Higgins-
DLR, Troll-
K-SAT

Malindi-ASI

GSE co

Living Planet



Industry Archiving Centre (incl Commerc.missions) shared by ESA



National Archiving centers shared by ESA



ESA Reference archive



Eumetsat Central Archive; SAFs not considered

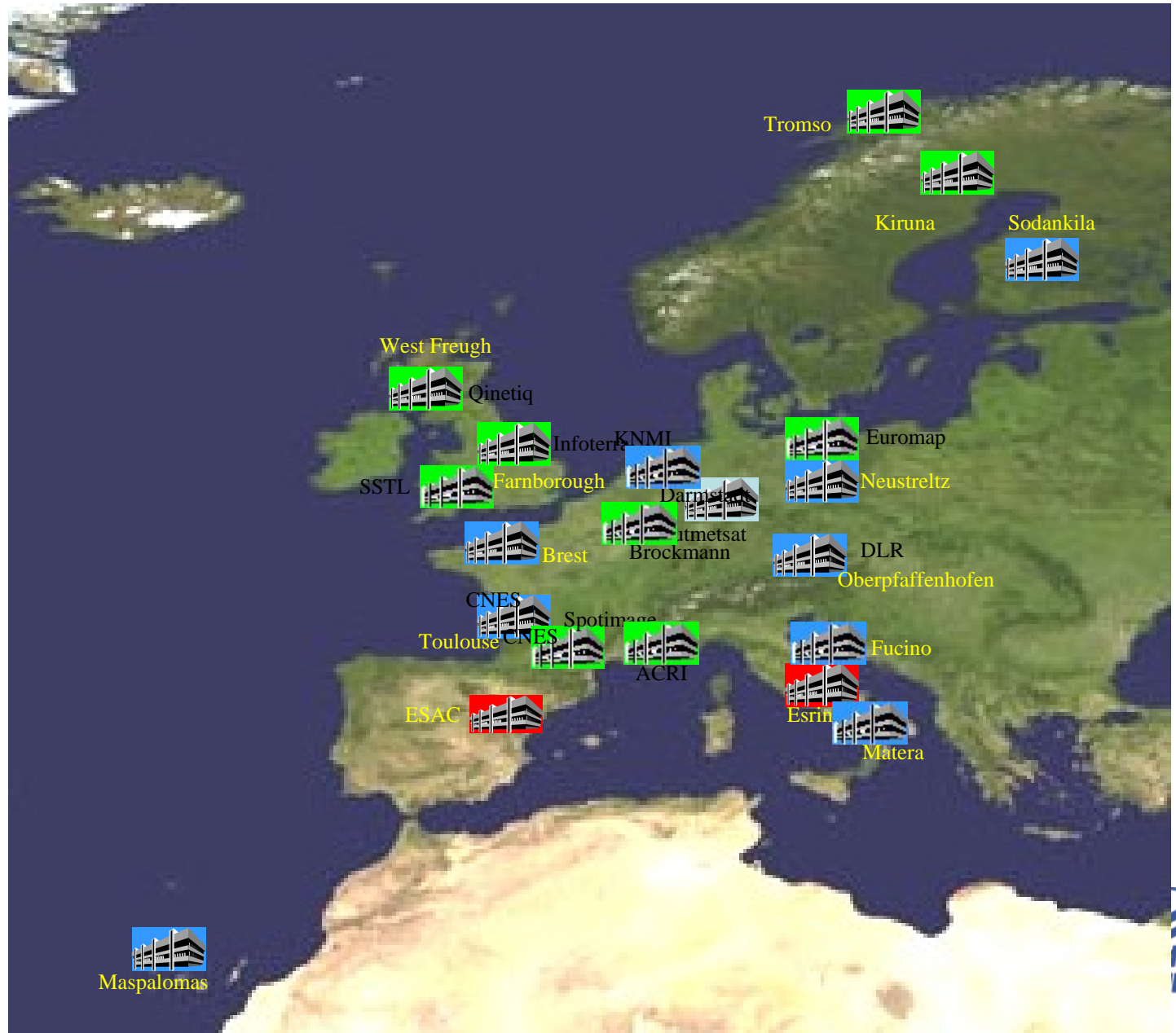



Maspalomas

Contributing Missions

CORE PROCESSES

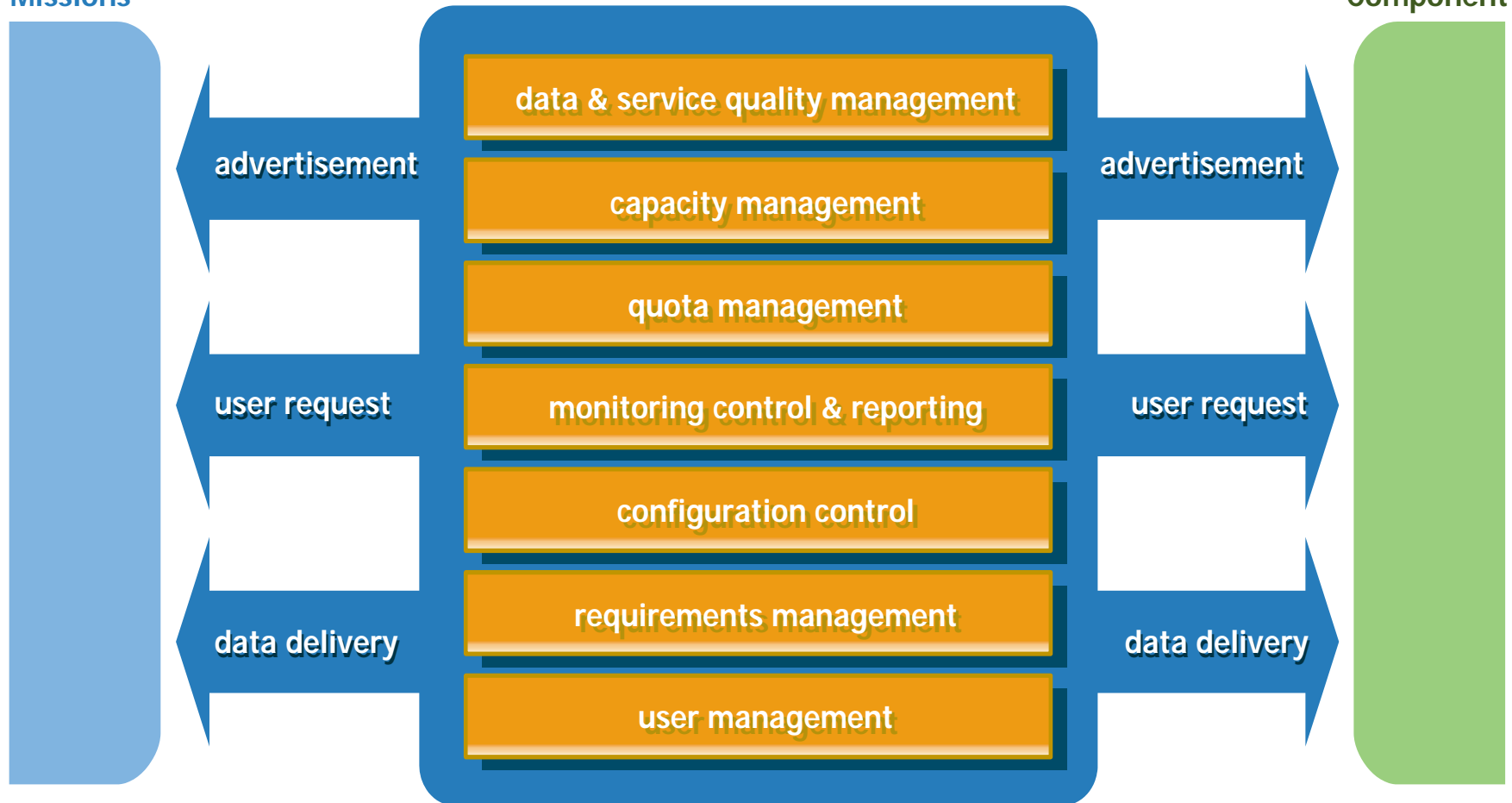
Service Component

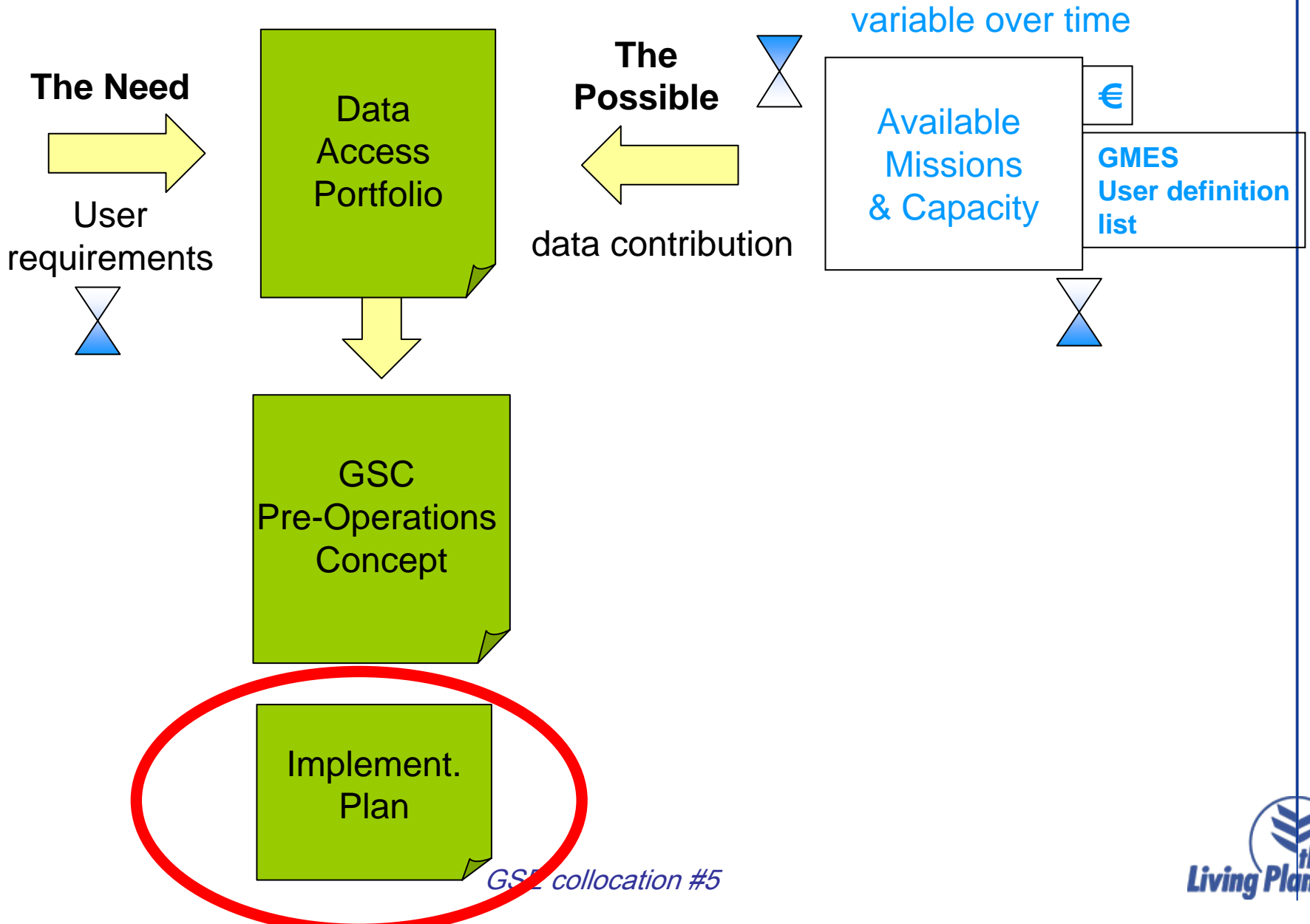



Multiple Missions	Management of Space Resources	Management of Ground Segment Resources	Access to Space Resources	Access to GS Resources	Example(s)	Comments
Independent					Quick Bird, Radarsat	No catalogue
Federated				X	Spot	Catalogue yes, order no
Cooperative			X	X	Landsat, Spot (planned) ENVISAT, ERS	Catalogue yes, Order yes
Loosely coupled - Collaborating		X	X	X	ALOS, COSMO - Pleiades	Catalogue, order, some mission planning
Tightly Coupled - Integrated	X	X	X	X	Cosmo-SAOCOM	Delegation of mission planning for ROI and/or Time
Integrated	X	X	X	X	Tandem-X	Orbit control

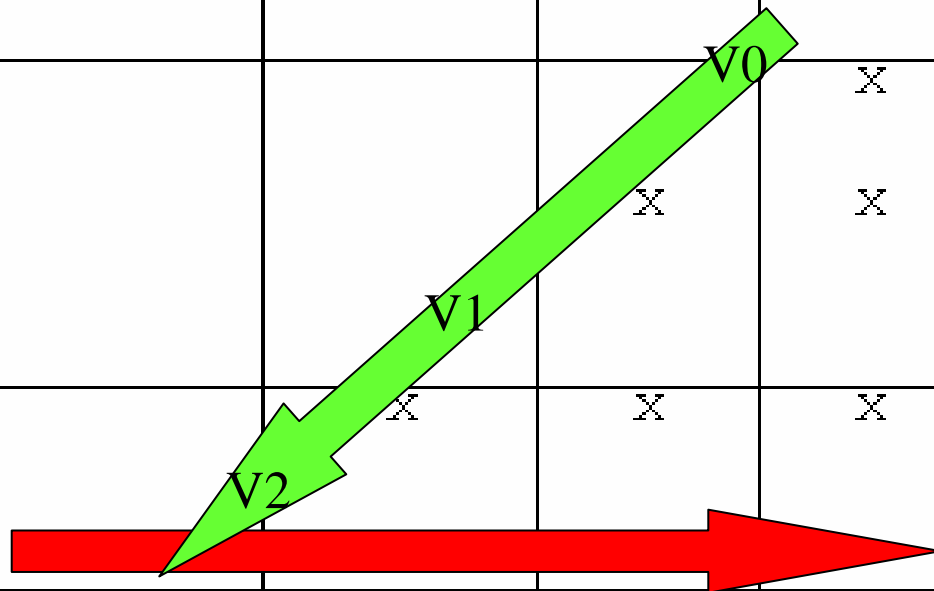

Mission classification based on resource access and management

GSE collocation #5

Staged approach

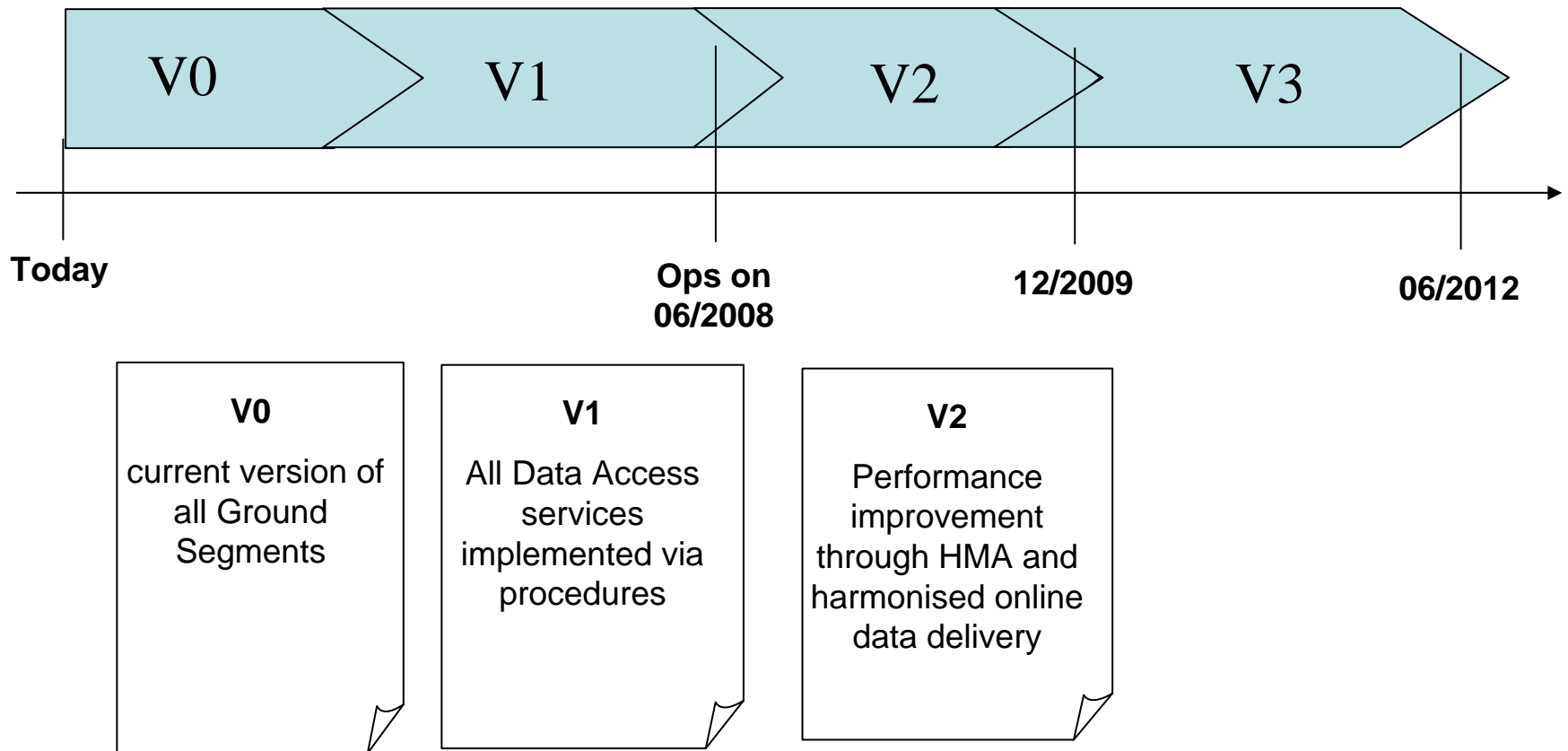

Thank you