

LIDAR-Based GN&C for Automatic Rendezvous and Safe Landing

Study Synthesis and Recommendations

MDR-LBG-TM.012

Issue A

UNLIMITED RIGHTS NOTICE

These data are submitted with unlimited rights under Contract No. 17406

Company

Date

Prepared by : A. ALLEN

MDA Space Missions

27 JULY 05

DISTRIBUTION LIST

Quantity	Company / Department	Name
1 (email)	ESA	D. Fertin

CHANGE RECORD

Issue	Revision	Date	Description
DRAFT	0	06/06/05	First issue of Technical Note
DRAFT	1	06/07/05	Incorporated NGC Aerospace comments
A	0	27/07/05	Final version

TABLE OF CONTENTS

EXECUTIVE SUMMARY – AUTOMATIC RENDEZVOUS

1	INTRODUCTION	8
1.1	Purpose of Document	8
1.2	Outline of Document	8
1.3	Acronyms and Definitions.....	8
1.4	Applicable Documents.....	9
1.5	Reference Documents	9
2	STUDY SYNTHESIS	11
2.1	Design Reference Mission	12
2.2	Lidar Review	12
2.3	Lidar Model and Imaging Model Definition	13
2.4	Functional Engineering Simulator Development.....	14
2.5	Analysis and Selection of Navigation, Guidance, and Control Algorithms	15
2.6	Design and Implementation of Navigation, Guidance, and Control Algorithms	17
2.7	Performance Assessment of Automatic Rendezvous Simulator	18
2.8	Performance Assessment of GN&C Algorithms	19
2.9	Real-time Test Bench - Hardware-in-the-Loop	20
3	RECOMMENDATIONS FOR FUTURE WORK	21
3.1	Additional Modelling within Simulator	22
3.2	Validation Testing.....	22
3.3	GN&C Improvements	22
3.4	Simulator Operability Improvements.....	23

Executive Summary - Safe Landing

1	INTRODUCTION	26
1.1	Purpose of document	26
1.2	Outline of Document	27
1.3	Definitions, Acronyms and Abbreviations.....	27
1.4	Applicable Documents.....	28
1.5	Reference Documents	28
2	BACKGROUND AND OBJECTIVES OF THE STUDY	29
2.1	Study Background and Overview	29
2.2	Study Objectives and Scope.....	29
3	SUMMARY OF THE ACHIEVED WORK.....	30
3.1	TASK 1: Support to the Consolidation of System Level Hypotheses.....	30
3.2	TASK 2: Analysis of Navigation Algorithms for Smart Landing.....	31
3.3	TASK 3: Analysis of Robust Guidance Techniques for Smart Landing	31
3.4	TASK 4: Support the Analysis of GNC Algorithms for Rendezvous.....	33
3.5	TASK 5: Enhancement of the Scene-Generation Software and Lidar Model.....	33
3.6	TASK 6: Definition of GNC Functional Simulator for Smart Landing.....	33
3.7	TASK 7: Development of the GNC Functional Simulator for Smart Landing	33
3.8	TASK 8: Detailed Design of GNC Algorithms for Smart Landing	35
3.9	TASK 9: Integration of Smart-Landing GNC Algorithms into Simulator.....	36
3.10	TASK 10: Performance Assessment of the Smart-Landing GNC Algorithms.....	37
3.11	TASK 11: Definition and Architecture of a Smart-Landing Test Bench.....	38
3.12	Lidar Requirement Specification Using a Top-Down Approach	39
4	SYNTHESIS OF THE STUDY RESULTS.....	41
5	RECOMMENDATIONS FOR FUTURE WORK	42

Description of Document

This technical note addresses the tasks contained in the following Work Breakdown Structure as specified in the original proposal numbered MDR-P.1576 (WBS 6.15). The outputs of this activity are provided in the form of technical notes (attached) for the rendezvous system development and the landing system development. The Study Synthesis and Recommendations for Automatic Rendezvous technical note (ARVSL-TN-012-MDR) starts on page 8 of this document. The Study Synthesis and Recommendations for Safe Landing technical note (ARVSL-TN-016-NGC) starts on page 23.

Study Synthesis and Recommendations

In this task the results obtained in this project will be consolidated and recommendations for follow-on studies will be made.

Activity Inputs:

- Outputs from all the Tasks.

Activity Description:

- Synthesise the results obtained in this project.
- Identify the work performed and the achievements.
- Provide recommendations for follow-on studies for real-time validation of LIDAR-based GN&C system for rendezvous and landing.

Activity Outputs:

- Technical note on the study synthesis and recommendations for future work.

Lidar-Based GNC for Automatic Rendezvous

Study Synthesis and Recommendations for Automatic Rendezvous

ARVSL-TN-012-MDR

Issue Draft

	Company	Date
Prepared by :	A. ALLEN	MD Robotics
		6 JUNE 05

DISTRIBUTION LIST

Quantity	Company / Department	Name
1 (email)	ESA	D. Fertin

CHANGE RECORD

Issue	Revision	Date	Description
DRAFT	0	06/06/05	First issue of Technical Note

1 INTRODUCTION

1.1 Purpose of Document

This document provides an executive summary of the work performed under the Lidar-based GN&C for Automatic Rendezvous portion of the contract and makes recommendations for future work in this area of study. Included is a discussion of the development and performance assessment of the Autonomous Tracking and Rendezvous Simulator (ATRS) which is designed to assist in the development of an autonomous rendezvous and proximity operations system (ARPOS).

1.2 Outline of Document

The document is organised as follows:

Section 2 gives a synopsis of the results and achievements of this study

Section 3 discusses the recommended future work

1.3 Acronyms and Definitions

ACS	Attitude Control System
AD	Applicable document
AOCS	Attitude and Orbit Control System
ARPOS	Autonomous Rendezvous and Proximity Operations System
ARVSL	Autonomous Rendezvous and Safe Landing (this program)
ATRS	Autonomous Tracking and Rendezvous Simulator
CAM	Collision Avoidance Manoeuvre
Control	The determination and execution of actions that bring, in a stable and accurate manner, the current dynamical state of the Orbiter coincident with the desired state.
DoF	Degree of Freedom
EHCW	Euler Hill Clohessy Wiltshire frame
EKF	Extended Kalman Filter
ERC	Earth Return Capsule
ESA	European Space Agency
FDI	Failure Detection and Identification
FoR	Field Of Regard (subset of the FoV)
FoV	Field Of View
GNC	Guidance, Navigation, and Control (also GN&C)
Guidance	The determination of the desired or reference Orbiter dynamical state
GN&C	Guidance Navigation and Control (also GNC)
HW	Hardware
IMU	Inertial Measurement Unit, composed of accelerometers and gyroscopes
IRU	Inertial Reference Unit, composed of gyroscopes
LIDAR	Light Detection and Ranging
LQS	Linear Quadratic Stationkeeping
LVLH	Local Vertical Local Horizontal
MAV	Mars Ascent Vehicle
MSR	Mars Sample Return
Navigation	The determination of the Orbiter dynamical state

NGC	NGC Aerospace Ltd.
OMS	Orbital Manoeuvring System
OSC	Orbiting Sample Canister
PRF	Pulse Repetition Frequency
RB	Requirements Baseline
Rbar	Axis on a vehicle and passing through the central body (\bar{R})
RCS	Reaction Control System
RD	Reference Document
RDF	Radio Direction Finder
RF	Radio Frequency
S/C	Spacecraft
SW	Software
TBC	To be confirmed
TBD	To be determined
TN	Technical note
TOA	Target Orbit Acquisition
UHF	Ultra High Frequency
Vbar	Axis on a vehicle and pointing in the direction of the vehicle velocity vector (\bar{V})
WBS	Work Breakdown Structure

1.4 Applicable Documents

The following documents contain requirements applicable to the activity:

[AD1] The ESA Error Pointing Handbook, WP-15, 19 February 1993. EHB-DGD-REP-002. [A1 in ITT/1-4334/02/NL/AG]

[AD2] “System Requirement Document”, Annex 1 of [3] above, available from ftp server. [A1 in July 8, 2003 Negotiation at ESTEC]

1.5 Reference Documents

The following documents contain references applicable to the activity:

[RD1] Aurora programme background: ftp://ftp.estec.esa.nl/pub/aurora/ESA-HQ_16-17_07_2002/ [R1 in ITT/1-4334/02/NL/AG]

[RD2] “Lidar-Based GN&C for Automatic Rendezvous and Safe Landing SOW”, TOS-ESN/DF/20020826, Issue 3.0, 29 Oct 2002, associated with the ESA ITT 4343. [R1 in July 8, 2003 Negotiation at ESTEC]

[RD3] “Lidar-Based GN&C for Automatic Rendezvous and Safe Landing” proposal, MDR-P.1576, MDR’s proposal to ESA, Feb 2003. [R2 in July 8, 2003 Negotiation at ESTEC]

[RD4] “Mars Sample Return SOW”, AURORA/AS/kc/002.03, Issue 2, 12 May 2003, associated with ESA ITT 4454. [R3 in July 8, 2003 Negotiation at ESTEC]

[RD5] “Mars Sample Return Assessment Study, Final Presentation, 18/02/2003, CDF-16FP, available from the web

[RD 6] MDR-LBG-TM.001 LIDAR-Based GN&C for Automatic Rendezvous and Safe Landing: SYSTEM LEVEL HYPOTHESES CONSOLIDATION

-
- [RD 7] MDR-LBG-TM.002 LIDAR-Based GN&C for Automatic Rendezvous and Safe Landing:
LIDAR TECHNOLOGY REVIEW AND LIDAR SELECTION JUSTIFICATION
- [RD 8] MDR-LBG-TM.003 LIDAR-Based GN&C for Automatic Rendezvous and Safe Landing:
ANALYSES, TRADE-OFF, AND SELECTION OF GN&C ALGORITHMS
- [RD 9] MDR-LBG-TM.004 LIDAR-Based GN&C for Automatic Rendezvous and Safe Landing:
LIDAR SOFTWARE MODEL – DESCRIPTION AND JUSTIFICATION
- [RD 10] MDR-LBG-TM.005 LIDAR-Based GN&C for Automatic Rendezvous and Safe Landing:
DEFINITION OF A RENDEZVOUS IMAGE SOFTWARE TOOL AND RENDEZVOUS
LIDAR MODEL
- [RD 11] MDR-LBG-TM.006 LIDAR-Based GN&C for Automatic Rendezvous and Safe Landing:
DEFINITION OF THE FUNCTIONAL ENGINEERING SIMULATOR
- [RD 12] MDR-LBG-TM.007 LIDAR-Based GN&C for Automatic Rendezvous and Safe Landing:
PROGRAMMATIC INPUTS – DEVELOPMENT PLAN OUTLINE SCHEDULE AND COST
ESTIMATES FOR FULL SYSTEM DEVELOPMENT
- [RD 13] MDR-LBG-TM.008 LIDAR-Based GN&C for Automatic Rendezvous and Safe Landing:
USER MANUAL FOR THE AUTONOMOUS PLANETARY LANDING SYSTEM
SIMULATOR
- [RD 14] MDR-LBG-TM.009 LIDAR-Based GN&C for Automatic Rendezvous and Safe Landing:
DETAILED DESIGN OF THE GN&C ALGORITHMS
- [RD 15] MDR-LBG-TM.010 LIDAR-Based GN&C for Automatic Rendezvous and Safe Landing:
PERFORMANCE ASSESSMENT OF LIDAR-BASED GN&C ALGORITHMS
- [RD 16] MDR-LBG-TM.011 LIDAR-Based GN&C for Automatic Rendezvous and Safe Landing:
REAL-TIME TESTBENCH DEFINITION FOR RENDEZVOUS AND LANDING

2 Study Synthesis

The objectives of the CDF Mars Sample Return (MSR) study were stated to be:

To study a “minimum” Mars Sample Return Mission validating, at reduced scale, technologies and operations for future human exploration.

In which the CDF study team intended that a “*minimum*” mission means that the requirements relevant to the sample are kept to a minimum and no scientific constraints on the landing site are imposed.

An early analysis by the ESA CDF team showed that a direct launch Mars-Earth return is unfeasible because the return vehicle leaving Mars would have a wet mass of 1500 kg. The descent stage to get such a vehicle to the surface alone would be >3500 kg. The analysis motivates the use of Mars Orbit Rendezvous to overcome this prohibitive vehicle mass.

The MSR mission is comprised of two separate flight segments. The first segment includes a Descent Module (DM) coupled with a Mars Ascent Vehicle (MAV) that can return a Sample Canister (SC) or an Orbiting Sample Canister (OSC) to Mars orbit. The second segment includes an Orbiter (that has the capacity to rendezvous with the OSC) and an Earth Return Capsule (ERC) to return the sample canister to Earth.

One of the stated goals was to baseline technologies available in the 2006-2007 timeframe. While several candidate technologies are of sufficient maturity to be considered for this operation, rendezvous operations, sensors, and docking mechanisms will require development and qualification. (The ExoMars Rendezvous Experiment (RVE) is designed to retire some of the risk associated with this development.) One of the candidate sensor technologies for the rendezvous is a scanning time-of-flight lidar.

Early in this study, a top-level concept of such a system, the Autonomous Rendezvous and Proximity Operations System (ARPOS), was described and the components of the system identified as follows:

- the ARPOS hardware, composed of a lidar and associated low-level software for data acquisition and formatting;
- the ARPOS software composed of high-level application software modules for implementation of the GN&C functions;
- the ARPOS interfaces with the Mars Orbiter and its GN&C system (with the sensors, actuators, software, and other subsystems necessary for the Rendezvous function)

The main technological innovation proposed in this study was the use of LIDAR as a range and direction sensor for autonomous relative navigation and rendezvous. The innovations can be summarised as follows:

- Hardware: the use of a LIDAR for accurate range and direction measurement to the co-orbiting target in Mars orbit.
- Navigation: the autonomous determination of the Local Vertical Local Horizontal (LVLH) attitude and attitude rates as well as relative position and velocities in the Target-centred Euler-Hill-Clohessy-Wiltshire (EHCW) frame for Mars orbit rendezvous.

- Guidance: the development of lidar-specific guidance functions for a Mars orbiter with respect to the EHCW frame with optional waypoints to enable ground-based supervision of an on-board autonomous system.

2.1 Design Reference Mission

The preliminary requirements presented in the proposal for this contract on the reference mission scenario, the mission-level requirements, the Orbiter design assumptions, the rendezvous requirements, the Lander design assumptions, and the landing requirements were reviewed and adapted following comments and mission guidelines provided by the Agency at the Kick-Off Meeting.

The reference rendezvous scenario and the associated Requirements Baseline that specifies the end-user requirements imposed on the development of ARPOS were developed. The Requirements Baseline includes:

- the applicable reference mission/spacecraft/hardware requirements and constraints
- Orbiter configuration and the GN&C equipment
- Orbiting Sample Container (OSC) configuration
- the reference rendezvous scenario and associated GNC system performance requirements (preliminary)
- a definition of the rendezvous phase
- initial and terminal conditions for the rendezvous
- the baseline requirements of the ARPOS operations

2.2 Lidar Review

A review of lidar technology was conducted with the intent of selecting the technology best suited to the design mission.

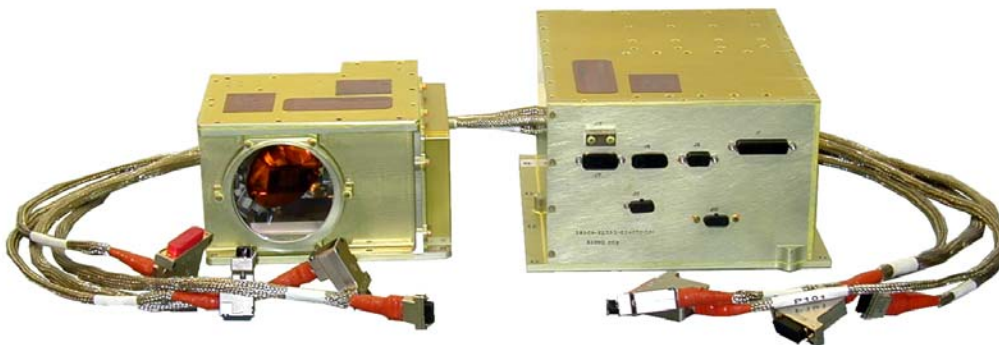

Figure 1: MDA/Optech Scanning ToF Protoflight Lidar

This survey incorporated the following elements:

- the requirements for a lidar-based GN&C system for autonomous rendezvous

- the requirements for a lidar-based GN&C system for safe landing
- the key performance parameters
- the construction of a metric by which various lidar solutions can be evaluated
- the performance parameters for a lidar system and derives a figure of merit which can be used as an aid in technology selection
- a survey of laser technologies for the transmitter
- a survey of scanner technologies for beam steering
- a survey of range measurement (ranging) techniques
- the identification of lidar sensors which have flight heritage
- a survey of new technologies that may influence future system development
- a description of the MDA/Optech lidar-based solution for relative navigation

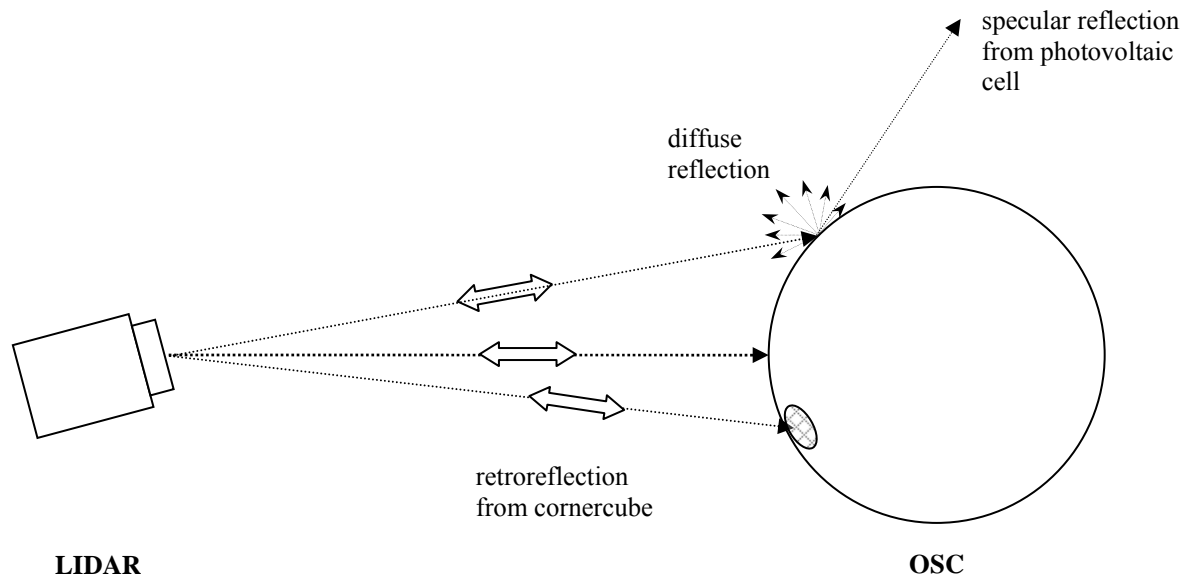

Figure 2: Lidar Image Generation Geometry for OSC

2.3 Lidar Model and Imaging Model Definition

The lidar model used in the autonomous tracking and rendezvous simulator was defined and described. This model is to be used during search and acquire, tracking, and throughout the terminal rendezvous stages. The module inputs, outputs, user-defined parameters and underlying functions were defined.

In addition, it was desired that the lidar be used to generate a three-dimensional representation (image) of a given spacecraft for proximity operations and for measurement of the target vehicle's relative attitude. This document defines the software module that is used for image generation of a given target spacecraft during rendezvous. This model is used within the ATRS once the range has dropped low enough to permit imaging (~150 m). The specific target

spacecraft in this study is the OSC (Orbiting Sample Canister) which is a spherical spacecraft with a 0.25 metre diameter covered with photovoltaic cells (80% coverage) and retroreflective targets. The spherical OSC simplifies the geometric transformations required to generate an image (Figure 2). A low-computation analytic solution to imaging the surface has been developed and implemented in the ATRS (Figure 3).

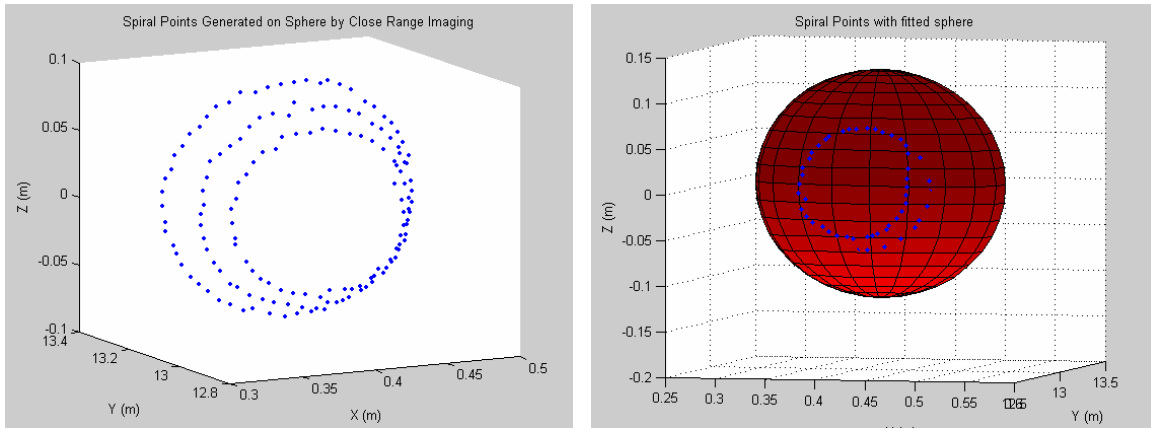

Figure 3: Imaging Mode on the ATRS

2.4 Functional Engineering Simulator Development

The functional modules that comprise the ATRS simulator and the interfaces between these modules were described in detail. Inputs to the simulator, the simulation environment, and simulator outputs and analysis are also defined. This definition included:

- the overall functionality of the simulator and a high-level description of its components
- the simulator design architecture, including inputs, outputs, and analysis, as well as the simulation environment in the MATLAB/Simulink engine
- a functional and in-depth discussion of each of the simulator modules in terms of functionality, modeling methodology and implementation, and theoretical underpinnings, as well as the interfaces and interactions between each of the modules

The Autonomous Tracking and Rendezvous Simulator comprises five main functional modules: navigation, guidance & control, thruster management, satellite propagation, and sensor measurement (Figure 4). Collectively, these modules model the system behaviour and the dynamics of the terminal phase of the rendezvous sequence about Mars.

At time equals zero, the modules derive input values from the initialisation file. In the nominal case, the chaser and target satellites are assumed to be in co-circular orbits about Mars, with the chaser lagging the target. The initial displacement of the chaser with respect to the target is specified in the input script, and fed into the simulator to initiate motion. Over the first simulation time step, the satellite propagation module calculates the subsequent position and velocity of the chaser satellite with respect to the target, as well as the chaser's orientation with respect to the inertial Mars frame. The sensor measurement module then uses this data to

produce position, velocity, and orientation measurements from the simulated sensory equipment models (Gaussian white noise is added to the data measurements to simulate distortion in the sensory equipment). Next, the navigation module employs an estimation filter to determine the state (i.e., position, velocity, and orientation) of the chaser satellite. The guidance & control module then uses these estimates to determine the relative orbit and orientation, and actuates an impulse vector and control torque on the chaser satellite necessary to advance the rendezvous with the target. This sequence repeats for every time step until the stop time of the simulation is reached. Throughout the simulation, output data is sent to the output module and/or the LVLH viewer for analysis.

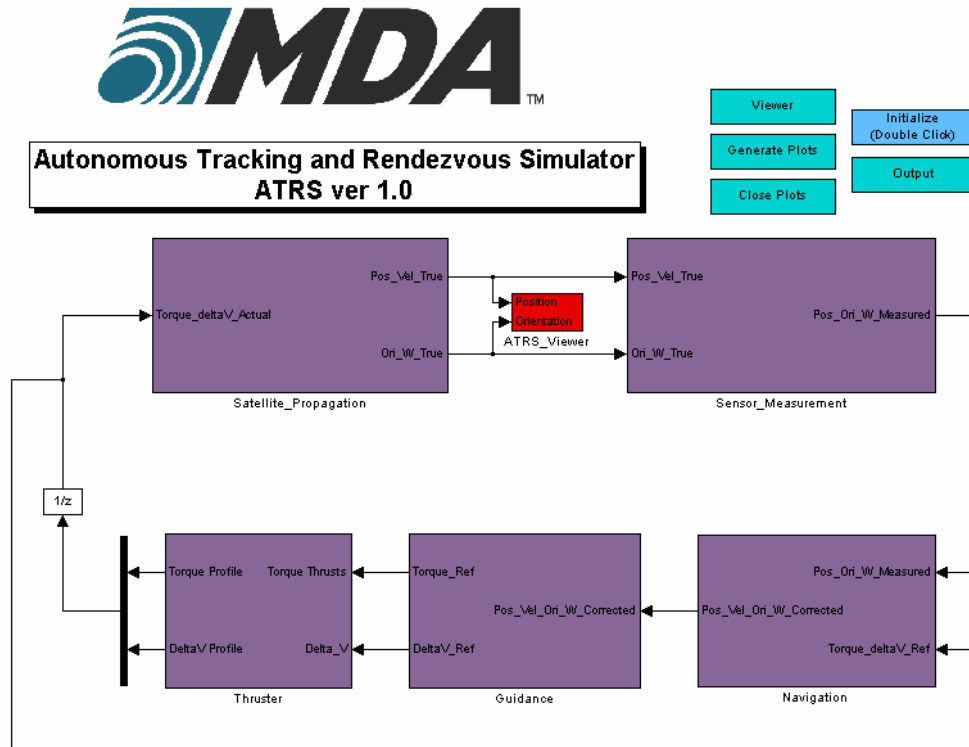

Figure 4: ATRS Top Level Functional Block

2.5 Analysis and Selection of Navigation, Guidance, and Control Algorithms

The algorithm selection criteria for the GN&C for the LIDAR-based Autonomous Rendezvous and Proximity Operations System are based upon the Requirements Baseline. The selection process included:

- a literature review
- development of strategy drivers and selection criteria
- an analysis of the techniques
- a discussion and justification of the selection

By way of example, Table 1 enumerates the overarching criteria used in selecting the appropriate guidance laws for the design reference mission. The guidance laws that were chosen and implemented are discussed further in Section 2.6.

Table 1: Algorithm Selection Criteria

Selection Criteria	Metric	Worst Case Failure	Other Failure Effect
Performance	trajectory convergence	loss of mission	increased rendezvous duration
Collision Safety	uncertainty ellipsoid	loss of mission	unnecessary CAM's
Robustness	perturbation rejection	loss of mission	increased rendezvous duration
Observability (Pointing)	lidar FoV	loss of mission	contingency CAMs
Fuel Optimal	ΔV requirement	loss of mission	reduced fuel availability puts pressure on schedule
Time Optimal	rendezvous duration	loss of mission	pressure on return-to-Earth launch window

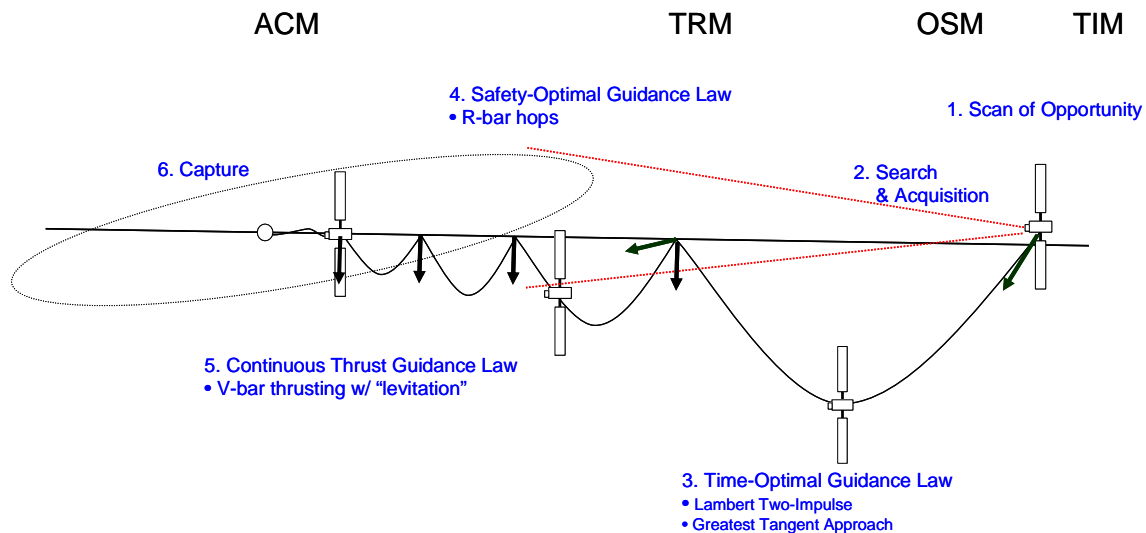

Figure 5: Terminal Guidance Scheme

2.6 Design and Implementation of Navigation, Guidance, and Control Algorithms

The design of GN&C modules of the ATRS was detailed prior to implementation. The following tasks were undertaken:

- a general functional overview of the GN&C modules
- a thorough description of the design of each module
- a discussion of the performance and robustness of the modules
- a discussion of the implementation, integration, and testing of the modules

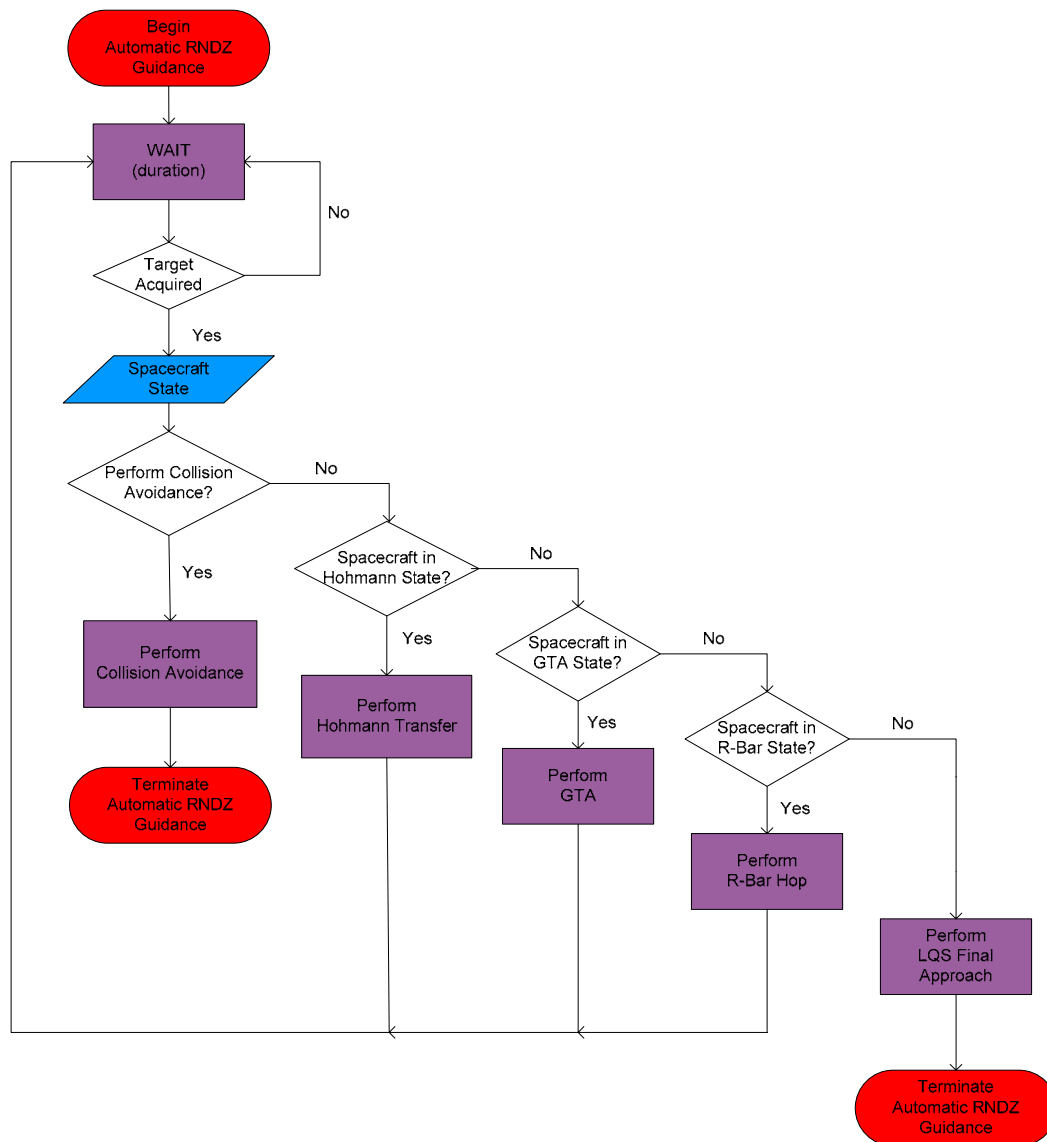

Figure 6: Guidance Law Scheduling Flowchart

The navigation module uses two optimal filters (one for orbit and one for attitude) to measure and predict the relative states of the two spacecraft based upon the measurements taken and a mathematical model of the relative dynamics of the vehicles. These states are then used by the guidance module to plan the trajectories and by the control system to execute those trajectories.

Figure 5 shows the guidance sequence that was selected for the MSR rendezvous. The selections are inherently safe incremental approach trajectories that respect the field-of-view (FoV) limitations of the lidar system. Each guidance law selected requires a module to compute the duration and the timing of the burns for that technique. Figure 6 shows the functionality of the code that schedules the various guidance laws to run.

The attitude controller selected and implemented in the ATRS is a thruster-based controller that uses hysteresis to prevent relay chatter that can plague bang-off-bang controllers. Figure 7 shows the premise behind the controller; the hysteresis softens the transition out-of and into the deadband and thereby prevents the rapid limit cycling that can waste fuel.

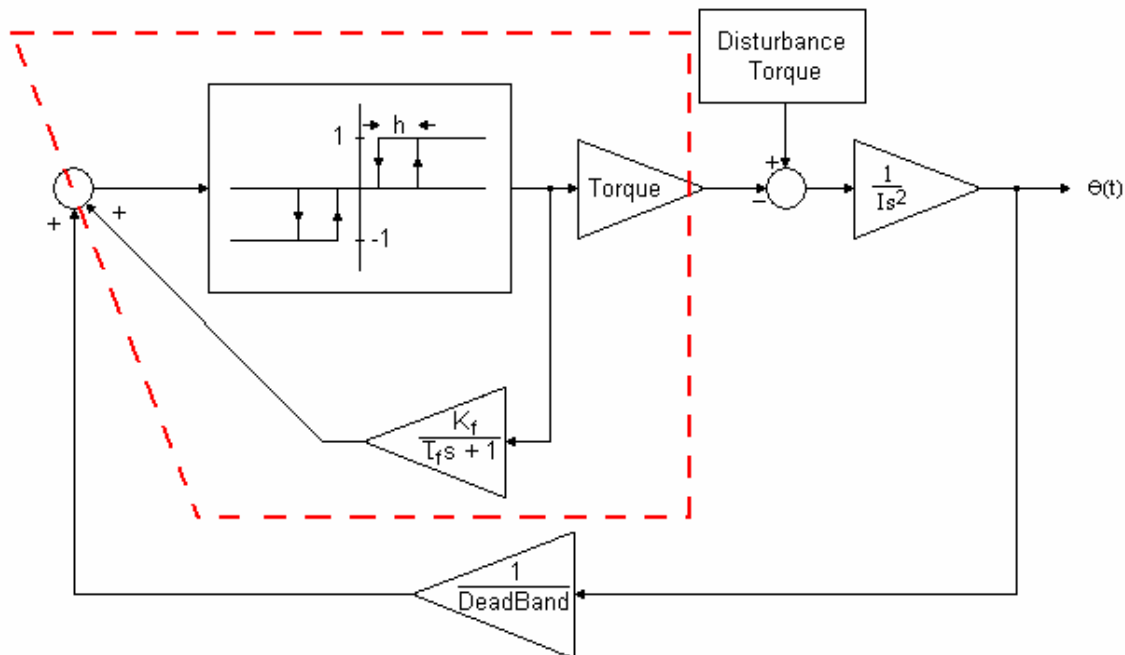

Figure 7: Attitude Control Schematic

2.7 Performance Assessment of Automatic Rendezvous Simulator

The end-to-end performance of the ATRS has been assessed through a series of tests of nominal rendezvous and via a large family of Monte Carlo runs designed to identify the sensitivity of operational success to various operational and sensor parameters. This assessment included:

- a description of the terminal rendezvous approach being assessed
- the parameters that can be varied within a simulation or family of simulations
- an assessment of the initial search and acquisition phase

- an assessment of the entire end-to-end terminal rendezvous
- a performance assessment of a unknown perturbation simulation
- an assessment of the end-to-end rendezvous for different initial conditions (Figure 8)
- a sample assessment of close approach using Monte Carlo techniques

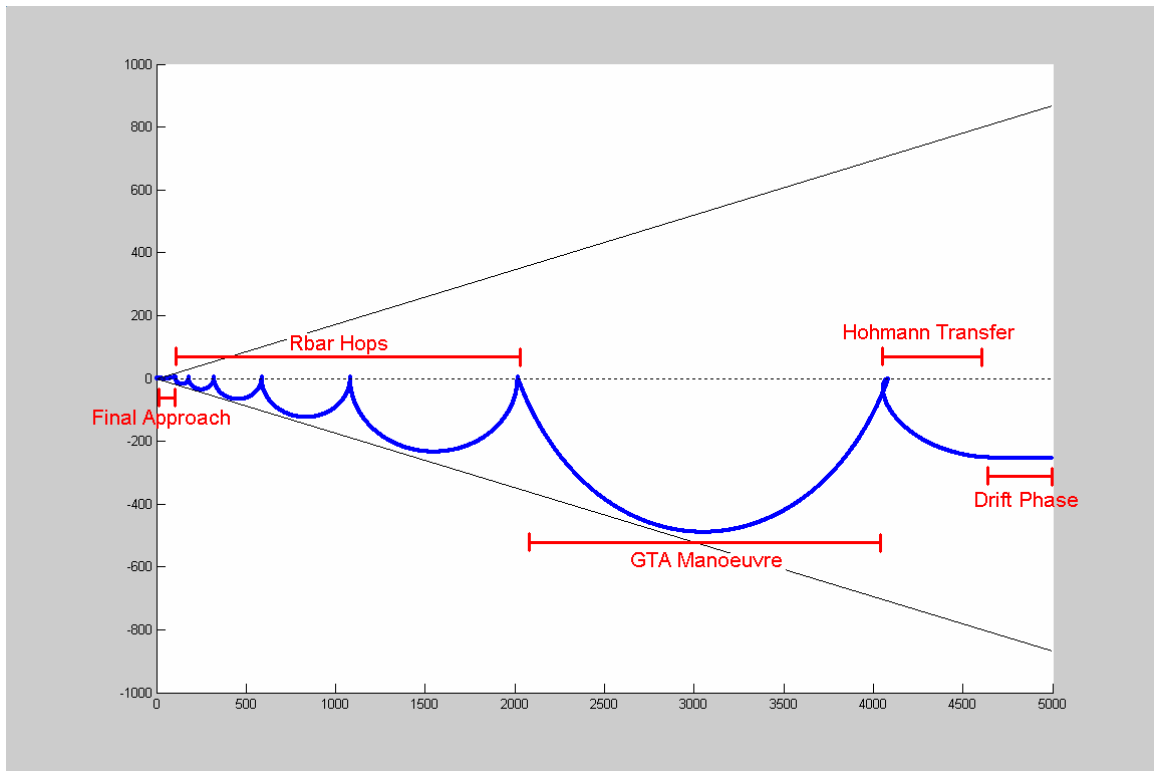

Figure 8: End-to-end Rendezvous Simulation

The plot in Figure 8 is well-matched to the conceptual guidance sequencing seen in Figure 5. In this case, however, the sequence begins with a fuel-efficient Hohmann transfer since the Orbiter found itself in a slightly lower orbit than the OCS.

2.8 Performance Assessment of GN&C Algorithms

The performance assessment of the navigation, guidance, and control algorithms was successful. The GN&C that was selected and implemented was able to repeatedly effect successful rendezvous in the presence of substantial sensor noise. Since no short range sensors were specified to assist with capture, there were some unsuccessful capture attempts due to high synthetic noise levels. There were no cases of failed rendezvous, however.

Figure 9 shows the results from the test run in which the chaser vehicle commences terminal rendezvous at a higher orbital altitude than the OSC. The blue plot line shows the in-plane motion while the red plot line shows the cross-axis motion superimposed. The plot on the left shows an initial manoeuvre followed by a series (8) of burns scheduled by the guidance law.

The plot on the right shows the final 70 metres under fine and continuous guidance. This run ended in the successful capture of the OSC.

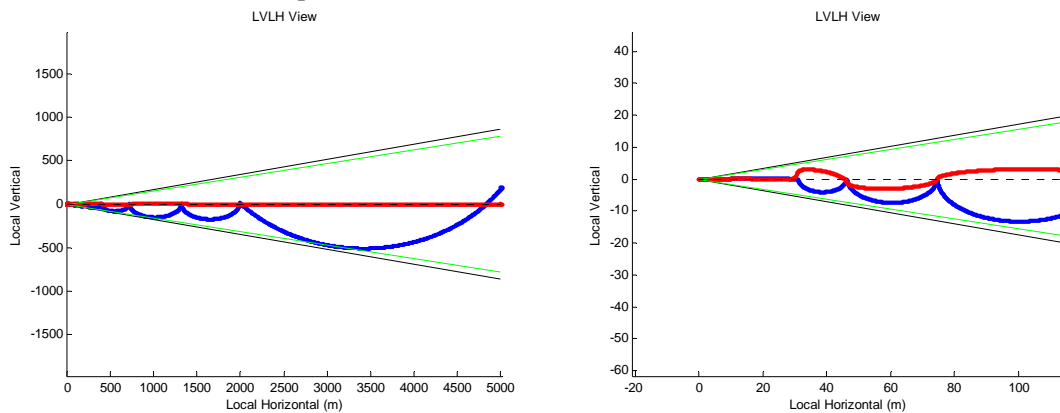

Figure 9: Performance Assessment - Chaser 200m above OSC Altitude

The left plot in Figure 10 shows the propellant required to execute each of the manoeuvres. The propellant used increases incrementally as manoeuvres are executed. The right plot shows the attitude control error, a weighted sum of the angular error and the angular velocity error, being contained within the prescribed deadband by the attitude control throughout the manoeuvres. Note that the period of this limit cycling is very long despite the apparent choppiness. The plot duration is that of the terminal rendezvous; the oscillations occur on the order on one orbital period.

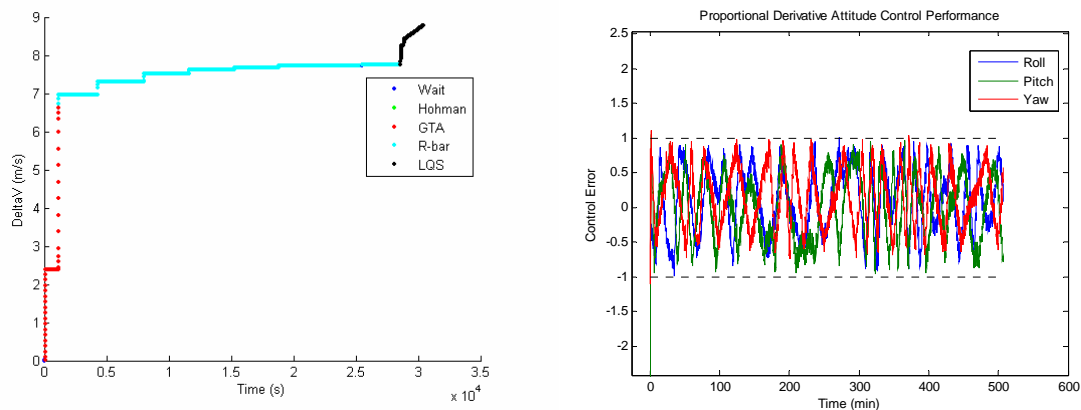

Figure 10: Chaser Above and Behind - DeltaV and Attitude Controller Performance

2.9 Real-time Test Bench - Hardware-in-the-Loop

The final task in this study was to define a hardware-in-the-loop test facility to reduce the technical risk associated with autonomous rendezvous in Mars orbit. A testing approach and facility architecture was defined for a real-time testbench for ARPOS. The definition included:

- a discussion of the methodology used in hardware-in-the-loop testing
- a functional requirements specification

Use or disclosure of data contained on this sheet is subject to the restriction on the title page of this document.

- a performance requirements specification
- an operations requirements specification
- a discussion of recent testing of lidar in a test bench (Figure 11)
- the configuration and architecture for a practical real-time test bench



Figure 11: Scaled Rendezvous Testing of HST

3 Recommendations for Future Work

The recommendations for future work fall into four categories; additional system modelling within ATRS, validation testing of ATRS and its components, added functionality to the GN&C, and operability improvements to ATRS.

Use or disclosure of data contained on this sheet is subject to the restriction on the title page of this document.

3.1 Additional Modelling within Simulator

The ATRS currently has a balanced level of fidelity; the key components have been modeled with similar degrees of complexity. The major components for assessing the operational use of lidar for rendezvous have been modeled. A few modules could be introduced, however, to extend the usefulness of the simulator for the assessment of other rendezvous sensors. Others could be added to extend the useful operational range of ATRS.

1. ephemeris models and associated functionality (e.g., eclipse, direct sunlight in sensor apertures)
2. contact dynamics modeling and hardware validation of the capture mechanism
3. reaction wheels for attitude control (e.g., momentum up until rendezvous allows for better disturbance rejection)
4. Radio Direction Finder (RDF) and Radio Frequency (RF) beacon model
5. close range sensor model (e.g., camera, stereocamera, flash lidar)
6. power budget modeling — may be linked to ephemeris models to see effectiveness of the rendezvous sensor suite over several orbits (rendezvous often drives peak and average power requirements for spacecraft)
7. attitude disturbance torques – either modeled or bounded (e.g., solar pressure, gravity gradient, fuel slosh)

3.2 Validation Testing

Integrated and unit testing using representative hardware allows the fine-tuning and validation of simulators. The validated simulator can then be used to investigate conditions that are impractical to test prior to flight.

1. scaled testing – proper scaled testing can produce representative results in certain cases
2. empirical testing of detection capability – detection capability at long ranges can only properly be quantified via testing
3. empirical testing of resolution and accuracy – resolution and accuracy models must be validated via testing
4. performance testing with mission parameters – as the MSR mission design evolves, updated performance testing can be used to evaluate the current baseline

3.3 GN&C Improvements

Additional functionality could be added to the guidance logic to allow for greater mission planning flexibility:

1. fuel vs. time dependent logic – this will allow the guidance scheduler to use slower trajectories if there is low propellant margin (and vice versa)
2. safety ellipse – the safety ellipse (‘football orbit’) provides an appealing way to stationkeep and inspect the Target (particularly if reaction wheels are modeled)
3. rate-matching trajectories – for conditions in which the Chaser spacecraft needs to match rates with the Target to capture or dock

3.4 Simulator Operability Improvements

The following are more mundane improvements to the current ATRS implementation that will nonetheless make the simulator more user-friendly. These changes are unavoidable if hardware-in-the-loop tests are desired.

1. run certain modules on separate machines (orbit/attitude propagation, lidar imaging and full-rate operation, spacecraft GN&C)
2. the simulator would run faster if a portion of the lidar model was Autocoded and placed in an S-function (the slowness is due to significantly higher sampling rates)
3. periodically subtract estimated rate bias from IMU — should improve quaternion measurement from IMU as the bias drift currently is not taken into account for that measurement

Lidar-Based GNC for Automatic Rendezvous and Safe Landing (ARVSL)

Study Synthesis and Recommendations for Safe Landing

ARVSL-TN-016-NGC
Issue Draft, Rev 0

		Company	Date
Prepared by :	DAVID NEVEU JEAN DE LAFONTAINE	NGC Aerospace Ltd	14 JUNE 2005
Reviewed by :	JEAN DE LAFONTAINE	NGC Aerospace Ltd	21 JUNE 2005



DISTRIBUTION LIST

Quantity	Company / Department	Name
1	MDA	R. Carr & A. Allen (by email)

CHANGE RECORD

Issue	Revision	Date	Description
DRAFT	0	21 June 2005	First issue of the document



1 INTRODUCTION

1.1 Purpose of document

This document presents the executive summary of the Lidar-based GNC for Automatic Rendez-Vous and Safe Landing (ARVSL) for the tasks assigned to NGC Aerospace Ltd related to the hazard avoidance and safe landing issues.

First, this document recalls the objectives and background of the study. Then, the results of each task defined in the proposal are summarised. Comparisons between proposed and achieved results are presented. Results locally obtained within each task are then grouped together and from them, a synthesis is presented. Finally, this document gives recommendations for future developments associated with Smart Landing technologies.

In reference to the Work Package Description of RD1, this current document reports on the following activities:

Task 13: Support to MDR for the Synthesis and Recommendations (PH2, T7)

In this task, NGC will support the Prime Contractor MDR in the preparation of a synthesis of the study results regarding the smart-landing tasks and the preparation of recommendations for follow-on studies regarding the real-time validation of a LIDAR-based GNC system for smart landing.

Activity Inputs:

- Outputs from all the NGC Tasks on smart landing.

Activity Description:

- Prepare a synthesis of the study results.
- Provide recommendations on follow-on activities.

Activity Outputs:

- Contribution to a MDR Technical note on the study synthesis and recommendations for future work.



1.2 Outline of Document

This document is organized as follow:

Section 2 Recalls briefly the background and the main objectives of the study.

Section 3 Summarized the work performed by NGC.

Section 4 Presents a synthesis of the results.

Section 5 Recommends follow-on activities.

1.3 Definitions, Acronyms and Abbreviations

APLS	Autonomous Planetary Landing System
APP	Mode of Operation: Approach
Control	The determination and execution of actions that bring, in a stable and accurate manner, the current dynamical state of the Lander coincident with the desired state.
CTL	Control functions
DOF	Degrees Of Freedom
EDLS	Entry, Descent and Landing System
EKF	Extended Kalman Filter
ESA	European Space Agency
FDI	Failure Detection and Identification
FOR	Field Of Regard (subset of the FOV)
FOV	Field Of View
GDC	Guidance functions
GNC	Guidance, Navigation and Control
Guidance	The determination of the desired or reference Lander dynamical state
ICD	Interface Control Document
IMU	Inertial Measurement Unit
IRD	Interface Requirements Document
IRU	Inertial Reference Unit
NAV	Navigation functions
Navigation	The determination of the Lander states and the assessment of the landing site safety.
NGC	NGC Aerospace Ltd
OBC	On-Board Computer
OBSW	On-Board Software
OL	Mode of Operation: Open Loop
P/L	Payload
RB	Requirements Baseline
RWSW	Real-World Software
S/C	Spacecraft
SDE	Software Development Environment
SSS	Mode of Operation: Safe Site Search
SW	Software
TD	Mode of Operation: Terminal Descent



1.4 Applicable Documents

AD1 ESA Software Engineering Standards, ESA PSS-05-0 Issue 2 ESA Board of Software Standardisation and Control (BSSC), February 1991.

1.5 Reference Documents

- RD1 Lidar-Based GNC for Automatic Rendezvous and Safe Landing, Technical, Management And Financial Proposal, NGC Aerospace Ltd, PROP-APLRV-NGC, Issue 1, 1 Feb. 03.
- RD2 Lidar-Based GNC for Automatic Rendezvous and Safe Landing (ARVSL): Landing Scenario and Requirement Baseline, ARVSL-TN-001-NGC, Issue Draft, NGC Aerospace Ltd, 12 Feb 04.
- RD3 Lidar-Based GNC for Automatic Rendezvous and Safe Landing (ARVSL): Analysis, Trade-Off and Selection of Navigation and Guidance Algorithms, ARVSL-TN-002-NGC, Issue Draft, NGC Aerospace Ltd, 18 Feb 04.
- RD4 Lidar-Based GNC for Automatic Rendezvous and Safe Landing (ARVSL): Fuel Cost Maps, ARVSL-TN-003-NGC, Issue Draft, NGC Aerospace Ltd, 09 Mar 04.
- RD5 Lidar-Based GNC for Automatic Rendezvous and Safe Landing (ARVSL): ARVSL LIDAR MODEL, ARVSL-TN-004, Issue Draft, Rev 1, NGC Aerospace Ltd, 17 Sep 04.
- RD6 Lidar-Based GNC for Automatic Rendezvous and Safe Landing (ARVSL): ARVSL Terrain Generation, ARVSL-TN-005, Issue 0, NGC Aerospace Ltd, 20 May 04.
- RD7 Lidar-Based GNC for Automatic Rendezvous and Safe Landing (ARVSL): ARVSL Definition and Development of the NGC Functional Simulator for Smart-Landing, ARVSL-TN-006, Issue 0, NGC Aerospace Ltd, 26 May 04.
- RD8 Lidar-Based GNC for Automatic Rendezvous and Safe Landing (ARVSL): ARVSL Software Preliminary Design: Architectural Design Definition (ADD), ARVSL-TN-007, Issue 0, NGC Aerospace Ltd, 17 Sep 04.
- RD9 Lidar-Based GNC for Automatic Rendezvous and Safe Landing (ARVSL): ARVSL Facility for LIDAR-based Software Validation, ARVSL-TN-008, Issue 0, NGC Aerospace Ltd, 14 Jul 04.
- RD10 Lidar-Based GNC for Automatic Rendezvous and Safe Landing (ARVSL): ARVSL Software Detailed Design: Navigation Module, ARVSL-TN-009, Issue Draft, NGC Aerospace Ltd, 17 Sep 04.
- RD11 Lidar-Based GNC for Automatic Rendezvous and Safe Landing (ARVSL): ARVSL Software Detailed Design: Guidance Module, ARVSL-TN-010, Issue Draft, Rev 1, NGC Aerospace Ltd, 25 Sep 04.
- RD12 Lidar-Based GNC for Automatic Rendezvous and Safe Landing (ARVSL): ARVSL LIDAR Requirement Specification using a Top-Down Approach, ARVSL-TN-011, Issue Draft, Rev 0, NGC Aerospace Ltd, 17 Sep 04.
- RD13 Lidar-Based GNC for Automatic Rendezvous and Safe Landing (ARVSL): Smart Landing Simulator User Manual, ARVSL-TN-012, Issue Draft, Rev 0, NGC Aerospace Ltd, 07 Jan 05.
- RD14 Lidar-Based GNC for Automatic Rendezvous and Safe Landing (ARVSL): ARVSL Integration and Validation Tests of the SMART Landing GNC Algorithms, ARVSL-TN-013, Issue Draft, Rev 0, NGC Aerospace Ltd, 4 Mar 05.
- RD15 Lidar-Based GNC for Automatic Rendezvous and Safe Landing (ARVSL): ARVSL Performance Assessment of the Smart Landing GNC Algorithms, ARVSL-TN-014, Issue Draft, Rev 0, NGC Aerospace Ltd, 3 May 05.
- RD16 Lidar-Based GNC for Automatic Rendezvous and Safe Landing (ARVSL): ARVSL Definition of the Smart Landing Test Bench, ARVSL-TN-015, Issue Draft, Rev 0, NGC Aerospace Ltd, 28 Feb 05.

2 BACKGROUND AND OBJECTIVES OF THE STUDY

This section summarises the background and the objectives that were initially stated in NGC's ARVSL proposal.

2.1 Study Background and Overview

Planetary explorations missions have always – and will still for many years – rely on unmanned automated spacecraft to acquire the required scientific data to advance our knowledge of the universe. With the growing need from the science community to acquire samples for in-situ analysis or for their return to Earth laboratories, planetary mission planners are now concerned with the requirements to land the probe on the surface of the planetary body.

The need for smart and autonomous landing systems

In the early planetary landing missions, the main and only requirement was to ensure the structural survivability of the Lander. The terminal landing phase was performed either (1) with human in the loop (the Apollo missions); (2) in open-loop, without control of the landing dynamics, but using airbags to cushion the touch-down impact; or (3) semi-autonomously, using a radar altimeter to ignite nadir-looking thrusters shortly before touch-down to slow down the Lander to a soft impact. Concentrating on unmanned mission, both open-loop (PathFinder) and semi-autonomous (Viking) landings have been successfully achieved on Mars. However, none of the past missions had the capabilities to detect and avoid in real time dangerous landing areas, select a safe landing site and perform precision landing. Mission planners chose landing areas that exhibited rather smooth and non-hazardous surfaces, as could be determined from remote observations (ground-based or from orbit). Currently-planned and future landing missions will be more demanding. One reason is related to the 'scientific quality' of the landing area. It so happens that the surface samples of interest, from a scientific point of view, are precisely in rough and hazardous areas where "recent" meteoroid impacts have ejected sub-surface material to the surface. Missions aimed at in-situ analyses or sample return to Earth will need to land in unstructured, unknown and hazardous areas. Since the signal return time to most planetary bodies does not allow Earth-in-the-loop control, landing operations will need to be performed autonomously on board the Lander. On-board autonomy also has the potential for increasing mission reliability by avoiding open-loop, 'blind' control actions that may lead to mission failure, as it has happened in the recent past.

The proposed solution: an "intelligent" LIDAR-based landing system

In this study, it was considered that one of the best instruments that can support obstacle avoidance and precise landing is a LIDAR. Compared to other landing sensor technologies, the LIDAR has many desirable characteristics and advantages: high spatial resolution, independence from lighting conditions, it avoids problems of scaling by measuring directly the range and it could be used as a high-precision science payload.

A LIDAR sensor acquires thousands of range measurements to the target in its field of view and generates three-dimensional maps of the scanned terrain in sensor frame. Lander position, velocity and attitude relative to the surface are not explicit in those measurements. Similarly, the detection of obstacles and the identification of safe landing sites require further processing of these raw data.

The LIDAR hardware must then be coupled with on-board autonomous software that can extract "intelligent" data from the raw data so that higher-level forms of observables can be used – at lower bandwidth and data rates – in the on-board navigation, guidance and control system.

This study defines a LIDAR-based guidance, navigation and control (GNC) system adapted to autonomous safe landing on a planetary body. It provides, as a main contribution, the [APLS simulator](#) that consists of models of dynamics, sensors and actuators of a landing vehicle with on-board autonomous navigation, guidance and control algorithms.

2.2 Study Objectives and Scope

The objectives of this NGC contribution to the AURORA programme were to deliver to ESA:

- (1) a set of consolidated mission requirements, landing scenario and landing requirements to serve as reference and background assumptions to this study,

- (2) the definition of a GNC system (sensors, actuators, algorithms) adapted to the autonomous obstacle avoidance, safe site identification and soft landing on a planetary body,
- (3) a detailed assessment of the functional performance of the GNC system on a dedicated simulator,
- (4) a set of refined requirements on the LIDAR sensor,
- (5) a preliminary definition of a real-time test bench.

The emphasis of the work was on the navigation and guidance algorithms as well as on the development of the real-world simulator required to validate the algorithms in realistic, closed-loop simulations. Control laws were not the main focus of the project but were nevertheless developed to ensure the closed-loop operation of the GNC system.

3 SUMMARY OF THE ACHIEVED WORK

This section is separated by tasks that NGC has carried out in direct contribution to the study outputs or in support to the Prime Contractor. The information provided in brackets refers to the tasks in the ESA ITT (e.g. Ph1, T1 refers to Phase 1, Task 1).

In the ARVSL study, 16 technical notes were written, describing the work achieved to meet the objectives on Smart Landing. The following table lists the delivered technical notes. The results achieved in each major task of the study are describe din the next section.

Table 1: List of the Delivered Technical Notes

TN-001	Landing Scenario and Requirement Baseline
TN-002	Analysis, Trade-Off & Selection of Navigation and Guidance Algorithms
TN-003	Fuel Cost Maps
TN-004	Lidar Model
TN-005	Terrain Generation
TN-006	Definition & Development of GNC Functional Simulator for Smart Landing
TN-007	Software Preliminary Design: Architectural Design Definition (ADD)
TN-008	Facility for LIDAR-Based Software Validation
TN-009	ARVSL Software Detailed Design: Navigation Module
TN-010	ARVSL Software Detailed Design: Guidance Module
TN-011	Lidar Requirement Specification Using a Top-Down Approach
TN-012	Smart Landing Simulator User Manual
TN-013	Integration and Validation Tests of the Smart Landing GNC Algorithm
TN-014	Performance Assessment of the Smart Landing GNC Algorithms
TN-015	Definition of the Smart-Landing Real-Time Test Bench
TN-016	Executive Summary of the ARVSL Study

3.1 TASK 1: Support to the Consolidation of System Level Hypotheses

The initial steps of the study consisted in defining a reference landing scenario and in specifying the system requirements that were later used to validate the smart landing algorithms. Those tasks included:

- Definition of a realistic Mars landing scenario separated into four phases (Entry, Hypersonic Flight, Parachute and Propulsive Descent)
- Definition of the mission-level requirements including constraints considered appropriate to each of those phases
- Specification of the required safe landing conditions in terms of soft touchdown requirements and safe-site characteristics
- Definition of the reference spacecraft design, constraints and sensor characteristics

- Definition of the functional operational and performance requirements for the development of the proposed autonomous landing system.
- Definition of preliminary physical and data interfaces between the foreseen required subsystems.

❖ The results of these tasks were presented in RD2.

3.2 TASK 2: Analysis of Navigation Algorithms for Smart Landing

The next activities were aimed at the definition of the algorithms required to fulfil those requirements. Rigorous analyses of the candidate algorithms and the definitions of the related trade-offs were performed. The possible solutions were analysed and the appropriate algorithms selected. The main analyses that were performed were related to sensors raw-data processing, safe site search algorithms and the selection of the states estimation algorithms.

The principles of attitude correction and re-sampling were chosen to ensure acquisition of comparable Lidar frames during the descent. The concepts of cost maps analysis was chosen to search for a safe site on the surface from the Lidar processed measurements. The Extended Kalman Filter (EKF) was selected as the state estimation algorithm.

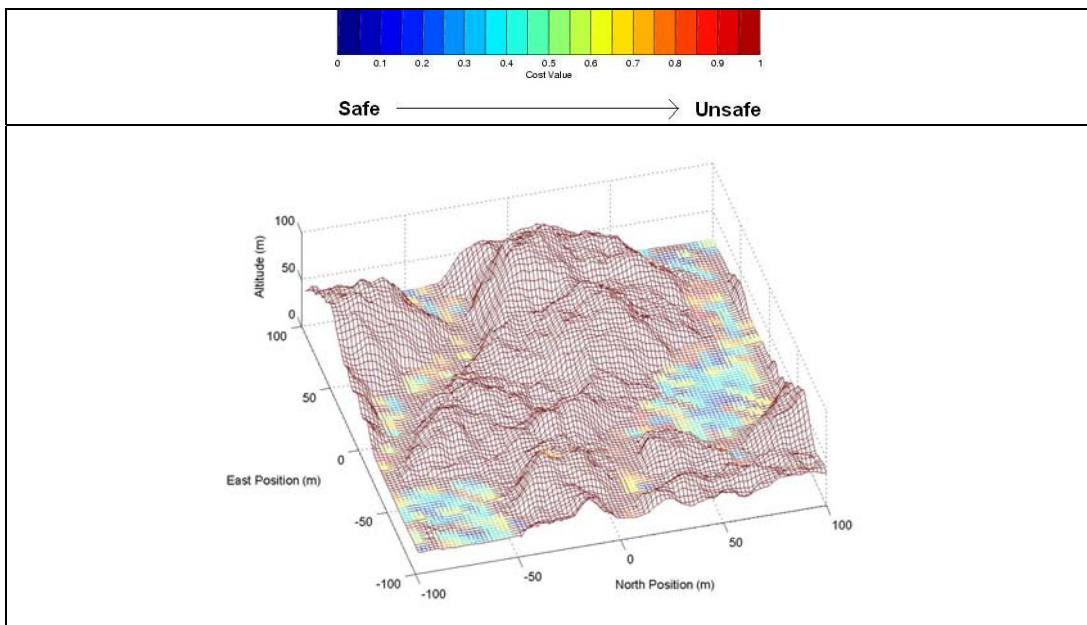

Figure 12: Color-coded Landing Terrain with Topographic Cost Maps Analysis

3.3 TASK 3: Analysis of Robust Guidance Techniques for Smart Landing

Analyses similar to the ones performed for the Navigation algorithms were also achieved for the selection of the Guidance techniques. Algorithms that had been already used in past landing missions were evaluated. Guidance laws used in Viking and Apollo missions was especially investigated and selected as relevant techniques.

❖ These analyses of the Navigation and Guidance algorithms were documented in RD3.

During Tasks 2 and 3, Navigation modes and Operational modes were defined to schedule the different GNC operations of the Lander during the descent.

Four Operational Modes were defined:

- DPA: Descent Profile Acquisition

- SSS: Safe Site Search
- APP: Approach
- TD: Terminal Descent.

Four Navigation Modes were also required:

- OL: Open-Loop Navigation
- ALT-VEL: Altitude and Velocity Navigation
- POS-SEARCH: Search for a Landing Site Navigation
- POS-TRACK: Track a Landing Site Navigation

The following table explains the interactions between these modes.

Table 2: Correspondence between Operational Modes and Navigation Modes

OPS Modes	DPA		SSS		APP	TD	
NAV Modes	OL	ALT-VEL	POS-SEARCH	POS-TRACK	POS-TRACK	OL	OL
Comments	We may have to start the DPA without valid LIDAR measurements	DPA using alt-vel navigation	Conditions for search are acquired; NAV still based on alt-vel	Cost maps provide position updates; APP starts only when estimator has converged	The state estimator has converged on the position of the safe site; can start the approach manoeuvre	Position-based NAV during the terminal descent	Loss of LIDAR before touchdown

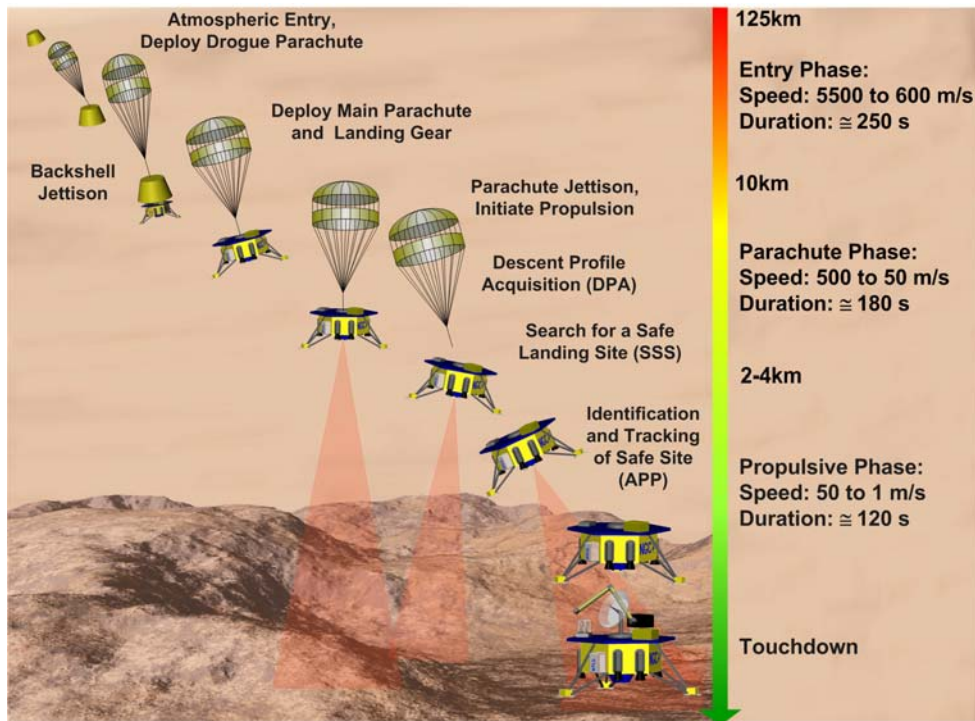

Figure 13: Mars Landing Scenario

Since the selection of one safe-site was only based on the analysis of the landing terrain through the use of topographic cost maps, an added feature was proposed. This addition, called fuel cost maps, ensured that the landing system not only identifies a safe site in terms of local slope and roughness but also in terms of the fuel consumption and manoeuvrability required to reach the site. These fuel cost maps were considered as guidance algorithms since the construction of such cost maps was dependent of the selected guidance law.

- ❖ The developments of the fuel cost maps were presented in RD4.

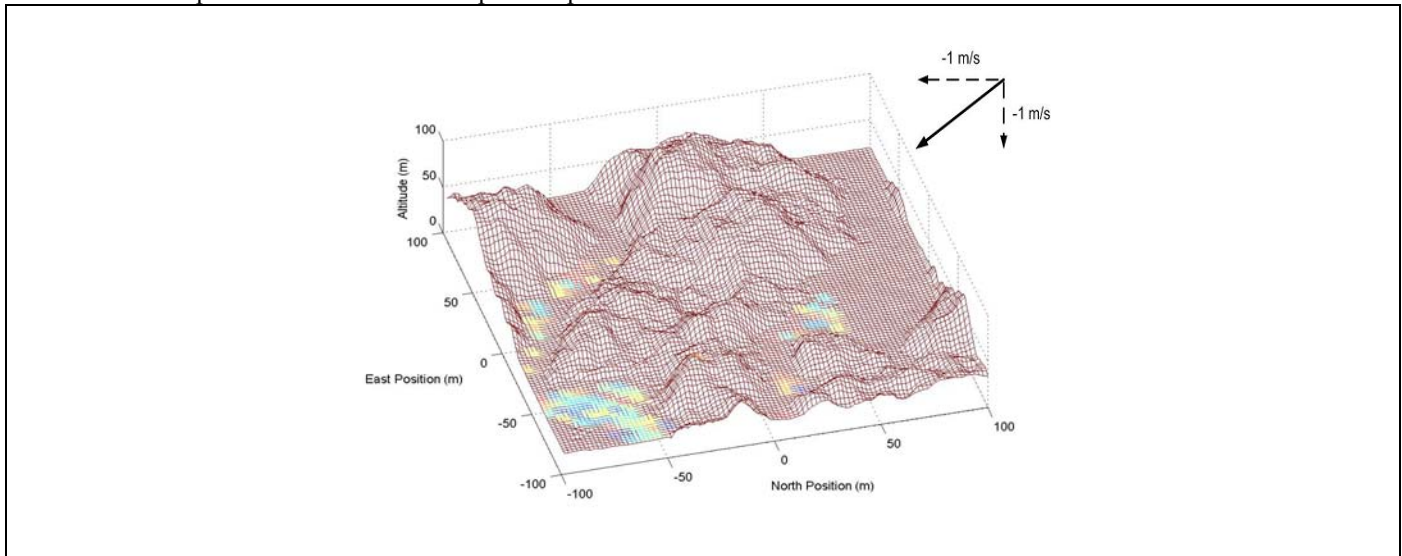

Figure 14: Color-coded Landing Terrain with Fuel Cost Maps Analysis

3.4 TASK 4: Support the Analysis of GNC Algorithms for Rendezvous

Some technical support was provided to MDR by NGC in terms of software development for Rendezvous.

3.5 TASK 5: Enhancement of the Scene-Generation Software and Lidar Model

Since the main sensor of the proposed Autonomous Planetary Landing System (APLS) is a Lidar, a mathematical model of the Lidar was developed to simulate the acquisition of terrain frames relative to a computer-generated terrain. With such a tool, closed-loop landing simulations and validations of the GNC algorithms were made feasible. Since the Lidar model was developed to be compatible with any computer-generated terrain, the Terragen[®] commercial software was also presented. It allows the computer generation of terrain according to the user's criteria for integration into the APLS software.

- ❖ The Lidar model was described in RD5 while the terrain generation tools were presented in RD6.

3.6 TASK 6: Definition of GNC Functional Simulator for Smart Landing

The next step consisted in defining the Real-World simulator (also called GNC functional simulator) to allow the functional and performance assessment of the GNC algorithms. Such software was required to simulate the spacecraft dynamics, sensors, actuators and environment. It was required to integrate in this simulator the previously developed Lidar model and develop an interface with the terrain generation software. The capability of performing automated Monte Carlo analyses in the simulator was also evaluated during this task.

3.7 TASK 7: Development of the GNC Functional Simulator for Smart Landing

The Real-World simulator was developed on MATLAB[®] based on the requirements defined in Task 6. Since the current NGC simulator was developed on MATRIXx[®] and not on MATLAB[®], several programming methods were investigated and tested to take advantage of the MATLAB/SIMULINK[®] different environment. New accelerometers and gyro models based on the HONEYWELL sensors specifications were integrated into the simulator. Models of Mars atmospheric density and wind were also integrated in the simulator.

- ❖ The developments of the GNC Functional Simulator were explained in RD7 and the user manual describing how to use the simulator was presented in RD13.

The following figure presents the GNC functional simulator interface developed in this study.

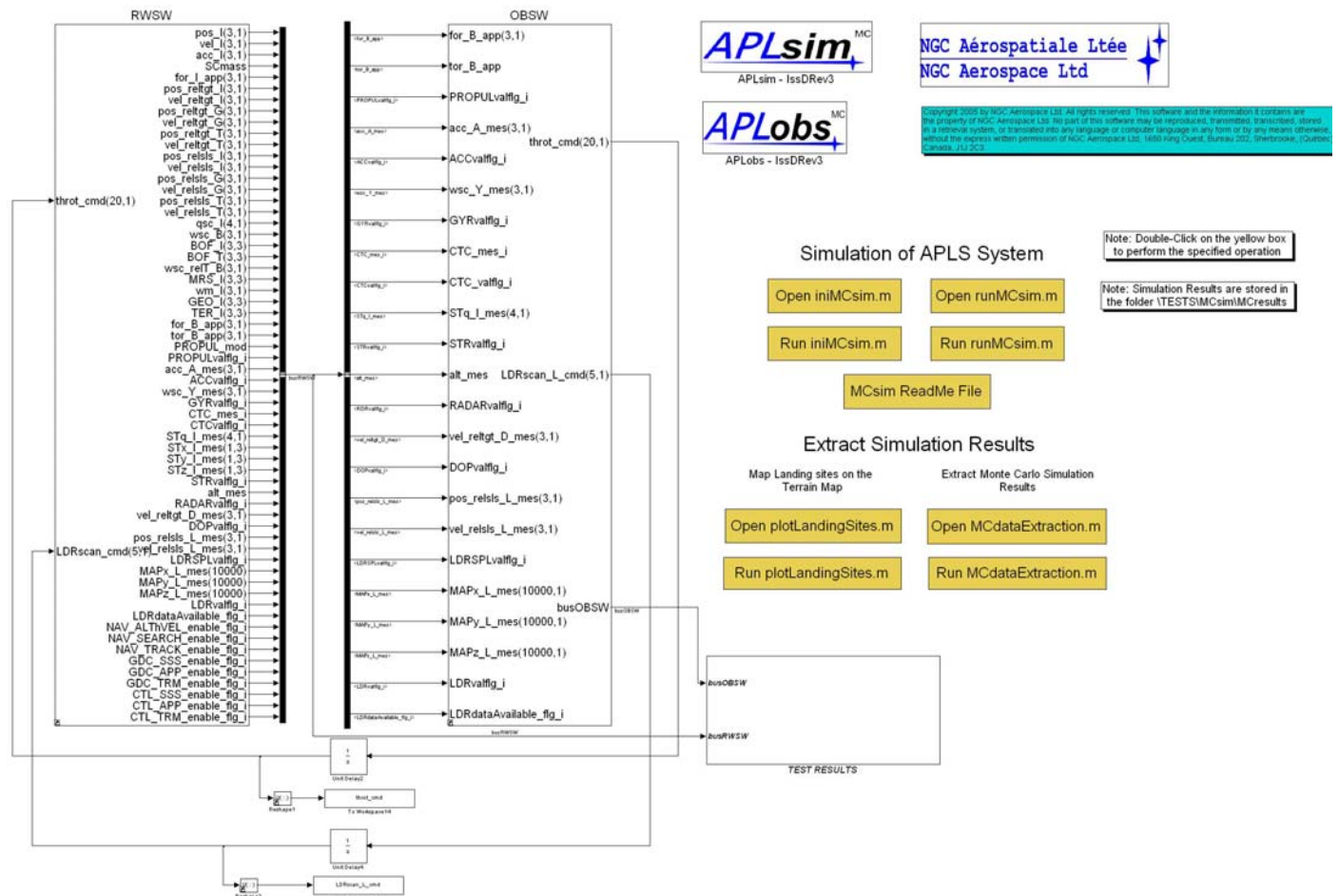

Figure 15: GNC Functional Simulator Interface

As the capabilities of performing software validation of the future GNC algorithms were in place, the previous developments achieved for hardware-in-the-loop validations were also presented. The test facility included an emulated Mars surface, the ILRIS 3-D Lidar delivered by Optech Inc, a chariot supporting the Lidar, and reference markings on the floor to perform semi-static experiments.

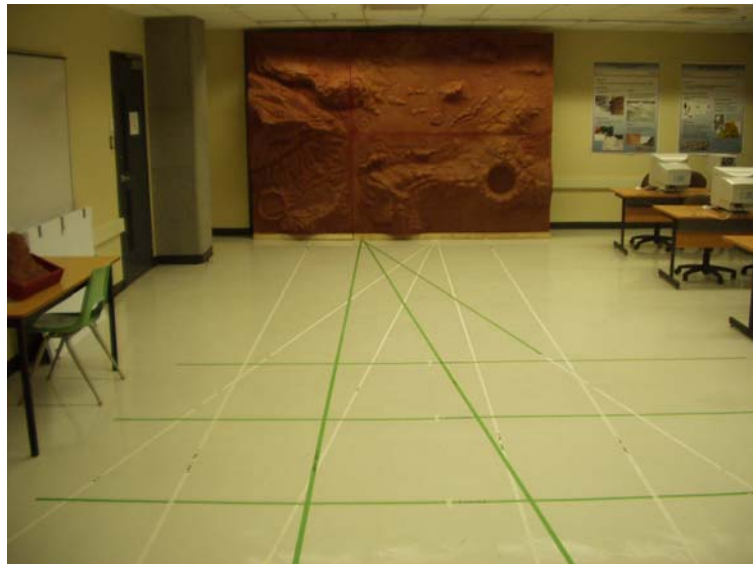
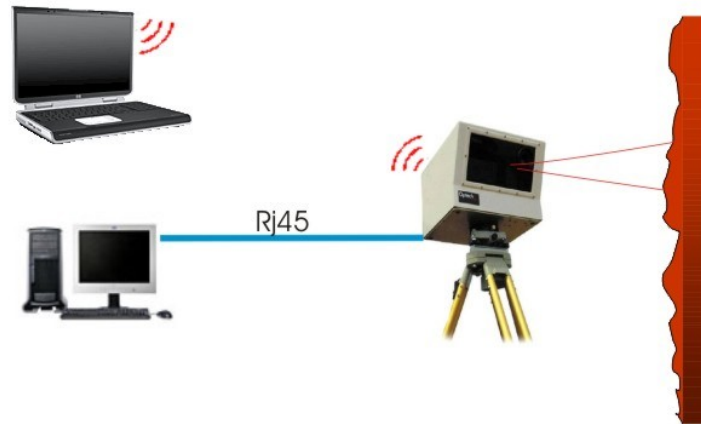

Figure 16: Semi-Static Laboratory Setup

- ❖ The semi-static laboratory setup was presented in the RD9 technical note.

3.8 TASK 8: Detailed Design of GNC Algorithms for Smart Landing

After completion of the Real World simulator, the smart-landing GNC algorithms selected in Tasks 2 and 3 were developed and designed in detail. The first steps consisted in defining the software architecture used to implement the GNC algorithms.

- ❖ The software preliminary design and architecture of the GNC algorithms are documented in RD8.

When the architectural design of the On-Board Software was completed, the Navigation, the Guidance and the Control functions algorithms were programmed and implemented in the software architecture.

Programming of the Navigation functions included the development of the following subsystems (Level-2 blocks):

- Measurements pre-processing functions (Lidar, gyro and accelerometers pre-processing)

- Navigation modes selection logic (NAV modes logic)
- Calculation of target position on the planet (target ephemeris)
- Calculation of the absolute attitude of the vehicle based on gyro measurements (relative to an arbitrary target plane)
- Estimation of attitude relative to surface normal plane
- State estimation algorithm in translation using Extended Kalman Filter (EKF)
- Calculation of Mean Surface Plane based altitude and normal plane (NAV_MSP)
- Computation of cost maps, normal plane and search for a safe site algorithm (NAV_SEARCH)
- Computation of cost maps, normal plane and safe site tracking algorithm (NAV_TRACK)
- Calculation of the gravitational accelerations
- Command of the Lidar sensor depending on the NAV modes.

Programming of the Guidance functions included the development of the following subsystems (Level-2 blocks):

- Operational (Guidance) modes selection logic (management of DPA, SSS, APP and TD mode flags)
- Calculation of the time vector used by the APP guidance algorithm
- Guidance algorithms in translation (Viking guidance, Quartic guidance and constant velocity guidance)
- Guidance algorithms in rotation (Velocity vector-based and Acceleration vector-based guidance).

Programming of the Control functions included the development of the following subsystems (Level-2 blocks):

- Control algorithms in translation
- Control algorithms in rotation
- Calculation of the control commands directed to each thrusters of the propulsion system.

The performance and robustness of each algorithm were demonstrated by analysis and, as required, using prototype software (unit tests).

- ❖ The design and analysis of the Navigation module was described in RD10 and the design and analysis of the Guidance module in RD11. The design of the Control module was not the subject of the present study but was nevertheless performed to allow closed-loop simulations.

3.9 TASK 9: Integration of Smart-Landing GNC Algorithms into Simulator

The major steps of the study were the integration of the Navigation, Guidance and Control functions into the GNC functional simulator and perform integration validation tests. To achieve those tasks, the validation tests were separated by modes of operation since the Navigation, Guidance and Control algorithms depend on the so-called Operational (OPS) and Navigation (NAV) modes (the reader is referred to Table 2). During this process of validation and integration, the following modifications and developments were required to ensure fulfilment of the mission requirements:

- Definition of the modes of operations of the state estimator depending on the type of measurements available. The Extended Kalman Filter (EKF) parameters required to be carefully chosen in order to minimise sensitivity to topographic noise and ensure convergence as quickly as possible.
- Definition of nominal conditions of landing used to validate the different algorithms.
- Introduction of an algorithm to prevent the update of the EKF if another safe site than the one detected during the Search mode (SSS) is detected during the Track mode (APP). This function was called the stiffness function or the update control algorithm.
- Addition of a new cost function, called Proximity Cost, designed to discriminate against new candidate landing sites and to encourage updates of the EKF. The combination of stiffness function with proximity cost contributed in improving substantially the tracking of a safe site during the APP mode.

After the integration and the validation process, the software already did ensure soft landing for a variety of initial conditions. This conclusion was based on limited number of simulations performed around the nominal conditions. These validation tests

were called here partial Monte Carlo simulations since the distribution of test conditions were restricted compared to the ones planned for complete Monte Carlo simulations.

❖ The validation and integration tests of the GNC algorithms were reported in RD14.

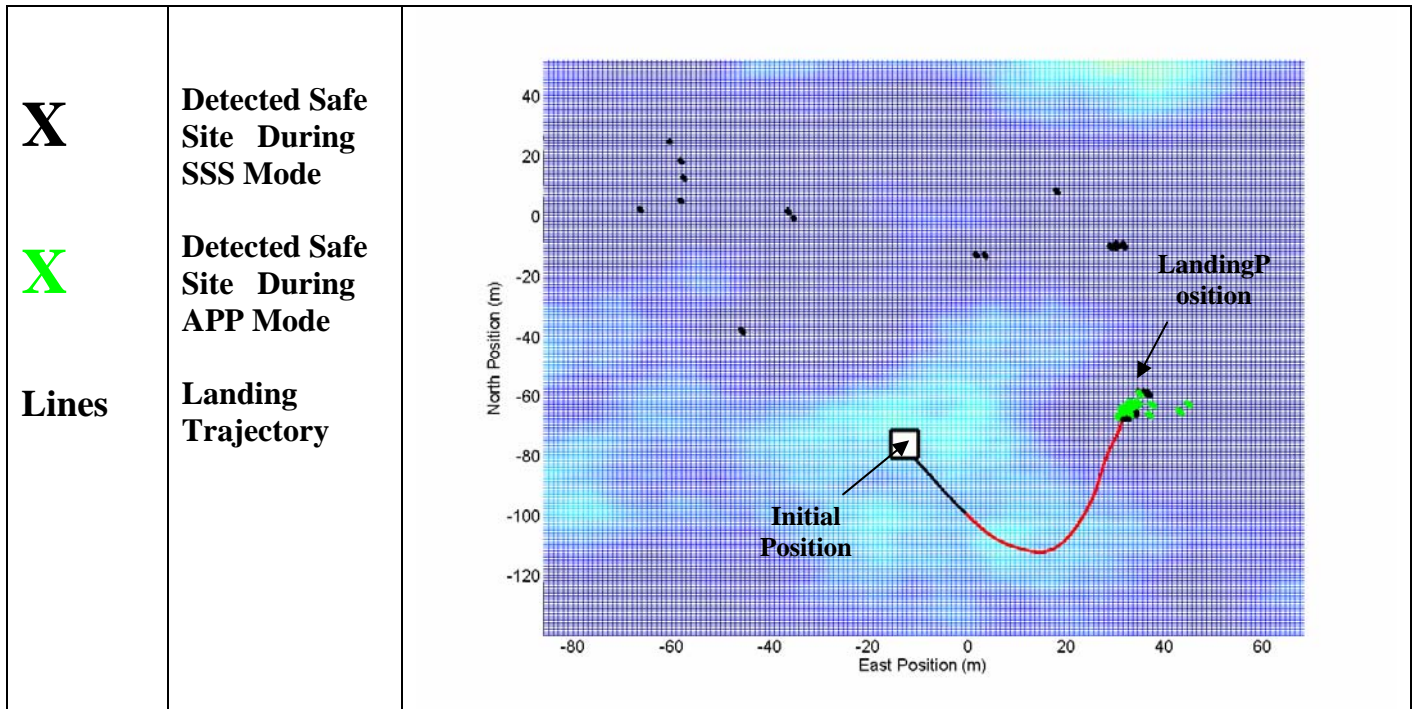

Figure 17: Example of Landing Trajectory

3.10 TASK 10: Performance Assessment of the Smart-Landing GNC Algorithms

Finally, as far as software performance assessment tasks were concerned, the last steps were to simulate the APLS software using Monte Carlo simulations by varying landing conditions. An important number of simulations were achieved with the following parameter variations:

- Variation of landing terrain topography (safe and hazardous areas)
- Variation of atmospheric disturbances (Gust and average winds)
- Variation of dynamic conditions
- Variation of spacecraft parameters
- Variation of accumulated state estimation errors
- Variation of sensors measurement errors and noise.

With these simulations, performances of the system were assessed and recommendations for future improvements to be applied to the software could be listed.

❖ The Monte Carlo simulations results were reported in RD15.

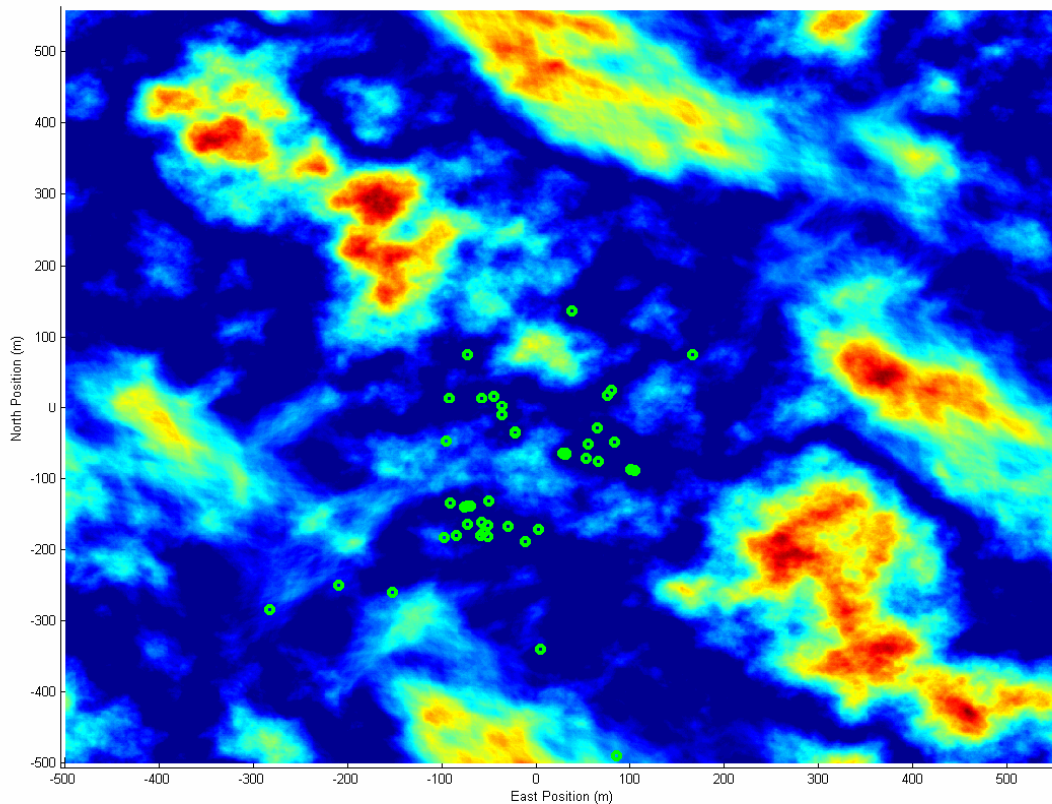

Figure 18: Example of Landing Positions for 50 Monte Carlo Simulations

3.11 TASK 11: Definition and Architecture of a Smart-Landing Test Bench

Among those last tasks accomplished in this study, the conceptual design of a real-time test bench for the end-to-end real-time simulation and analysis of the smart landing was developed. Numerical Monte Carlo simulations performed in this study made it possible to recreate the dynamical environment of a landing vehicle and to validate the entire closed-loop GNC software at a low cost. However, this type of validation has significant limitations compared to real hardware-in-the loop setups. With a dynamic test bench, the complexity of modelling the complete dynamics of the Lidar and the interactions with a surface are no longer required, hence the advantage of developing such an infrastructure.

The following tasks were accomplished:

- The test bed requirements were defined, including the need to perform scaled simulation of the autonomous planetary landing system with a real Lidar.
- The conceptual design and the required subsystems was presented.
- The architectural design including the three operational modes called simulated, laboratory and virtual modes were explained.
- ❖ The definition of the smart landing test bench was presented in RD16.

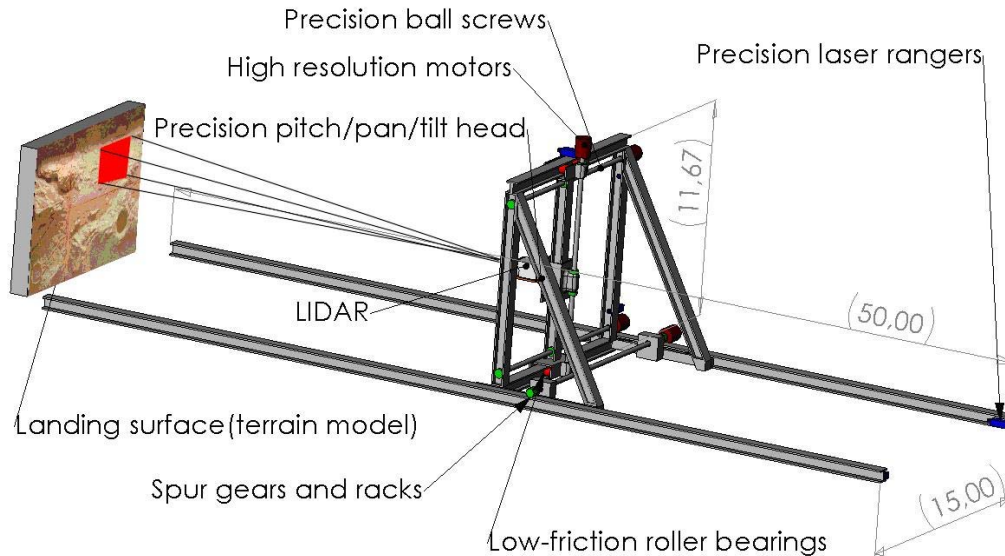

Figure 19: Example of Dynamic Test Bench Mechanical Design

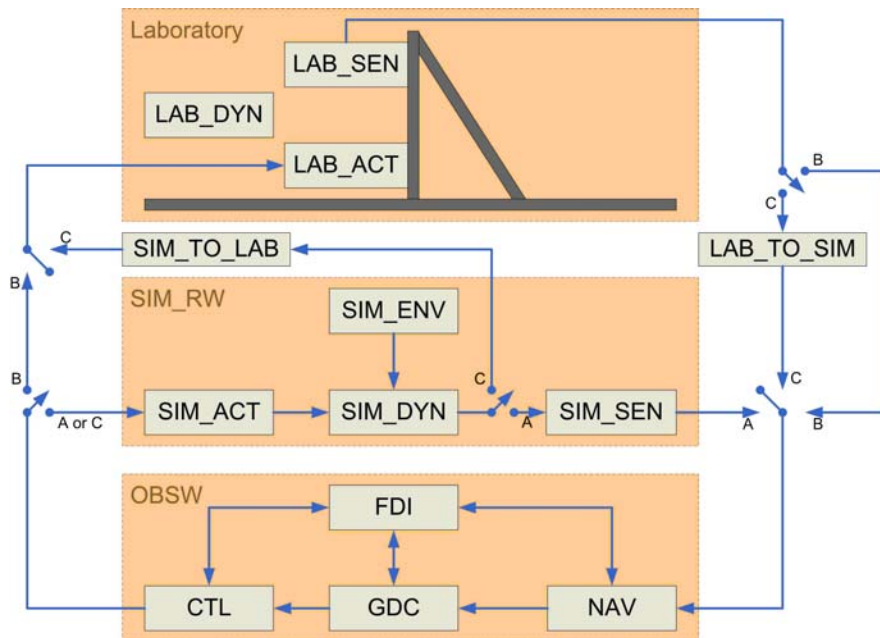

Figure 20: Real-Time Test Bench Software Architecture

3.12 Lidar Requirement Specification Using a Top-Down Approach

NOTE: This task was not originally foreseen in the NGC Proposal

The development of the landing scenario and GNC algorithms were based on the currently achievable performance with existing Lidar hardware. This bottom-up design approach was aimed at simplifying some of the trade-offs and decisions that had to be made at system level. The descent and landing scenario was thus designed to maximise the number of surface measurements – the so-called topographic cost maps – to ensure the detection and tracking of a safe site. However, under request from ESA, another design-specification approach was developed and presented by NGC. This new approach followed a top-down approach, starting from the top-level mission requirements to arrive at the required Lidar performance. The main objective of this new approach was to define the minimum descent scenario that would ensure mission success and derive from it the minimum Lidar performance. The following problems were addressed in this task:

- How many so-called topographic cost maps of the landing area are sufficient to find a safe site?
- How many times can the system afford to lose a safe site and search for a new one?
- What should be the minimum altitude of operation?
- What field of view and density of measurements (spatial resolution) would be required?

These questions were answered by developing analytically the relationships that links together the mission requirements (the amount of available fuel and the size of the search area) with the LIDAR requirements (spatial resolution and pulse repetition frequency). Those relationships were delivered in the form of formulas and graphs.

- ❖ This top-down design approach was presented in RD12.

4 SYNTHESIS OF THE STUDY RESULTS

Lidar-based planetary landing systems are very appealing technologies for future space exploration missions. This study has demonstrated by mean of software validations and analytical developments that such a technology using smart GNC algorithms is able to meet the requirements of a realistic Mars landing scenario.

The proposed and achieved results of the present study are the following:

- Definition of Smart landing systems requirements and definition of a realistic Mars landing scenario.
- Successful design of a Lidar-based GNC functional simulator on MATLAB/SIMULINK[®]. Several sensor models were included, atmospheric disturbances model, 7-DOF dynamic model and two different propulsion system configurations models.
- A Lidar model, part of the Real-World simulator, was successfully designed and tested, giving the ability to simulate the Lidar data acquisition over a complete landing trajectory of the vehicle above any user-defined landing terrains.
- A simple and cost-effective solution to generate terrains with Terragen[®] was proposed for their use with the APLS software.
- A successful design of the On-Board Software including autonomous Navigation, Guidance and Control functions was proposed and implemented on MATLAB/SIMULINK[®].
- Satisfying performances of the smart GNC algorithms were assessed by performing validations tests and complete Monte Carlo simulations. A success rate above 90% was obtained for fairly safe areas compared to approximately 85% in more hazardous areas.
- The APLS software including both the Real-world Software and the On-Board Software connected in closed-loop was delivered to the client. It included useful tools to run easily the Monte Carlo simulations, extract terrains from Terragen[®] and visualise the results.
- The computing performances of the proposed GNC algorithms are assessed to be near real-time. The major reason why a landing of 140s took approximately 450s to simulate is caused by the Lidar model of the Real-World Software which is based on iterative ray-tracing techniques and requires a large fraction of the simulator computing power capabilities.
- A preliminary design of a real-time test bench to improve the validation capabilities of Lidar-based smart landing technologies was also achieved during this study.
- Lidar requirements using a *top-down* approach were defined.

So far, an evaluation of the project against the performance criteria of the proposal is more than satisfactory. In fact, systems similar to the APLS are undergoing research and development in different organisations around the world and the results of our research presented in several conferences have already received considerable positive reactions.

5 RECOMMENDATIONS FOR FUTURE WORK

In the near future, a number of solar-system exploration opportunities will be announced; it is of first priority to continue the developments of the APLS system. Such developments must include the realisation of a dynamic test bed facility that will be used to qualify and improve with better accuracy the performances of the GNC algorithms, especially the autonomous Lidar-based navigation algorithms. It is also important to pursue the development of a more complete simulator that could include every scenario of landing on celestial body: large gravity with atmosphere (Mars, Venus), large gravity without atmosphere (the Moon, Mercury) and with micro-gravity (asteroids and comets).

For short-term considerations, we recommend should be to:

- Improve the current safe site search algorithm in order to minimise the time required to identify and converge toward a safe site. Slow safe landing site identification is the first cause of landing failure that was pointed out during the analyses of the Monte Carlo simulations.
- Enhance the horizontal velocity estimation algorithm by ensuring better safe site tracking or by implementing feature recognition tracking algorithms. This last possibility was the subject of a past study performed by NGC, but much work was still required to increase robustness of the techniques.
- Integrate the entry and the parachute phase into the APLS simulator to get a complete Mars landing simulator.